



**DYNATECH  
DYNAMICS AND TECHNOLOGY, S.L.**

**OVERSPEED GOVERNOR  
*VEGA Plus***

## **CONTENTS**

1.-	INTRODUCTION.....	1
2.-	MAIN COMPONENTS.....	1
3.-	WORKING PRINCIPLES.....	2
3.1.	Encoder.....	3
4.-	TECHNICAL FEATURES.....	14
5.-	INSTRUCTIONS OF USE AND MAINTENANCE.....	15
6.-	INSTALLATION DRAWINGS.....	15
7.-	EC TYPE-EXAMINATION CERTIFICATE.....	18

## 1.-INTRODUCTION.

Like the VEGA governor, the DYNATECH VEGA PLUS speed governor is designed, in the event of overspeed, to trip the safety gear where required.

The characteristic of the VEGA PLUS is that it is fitted with an Encoder for permanent information on the position of the car.

## 2.-MAIN COMPONENTS.

Each governor is composed of the following main elements: a pulley, a centrifugal system, a locking device, a casing and a plate to link the governor to the floor in the machine room.

The following picture shows an image of the governor assembly:

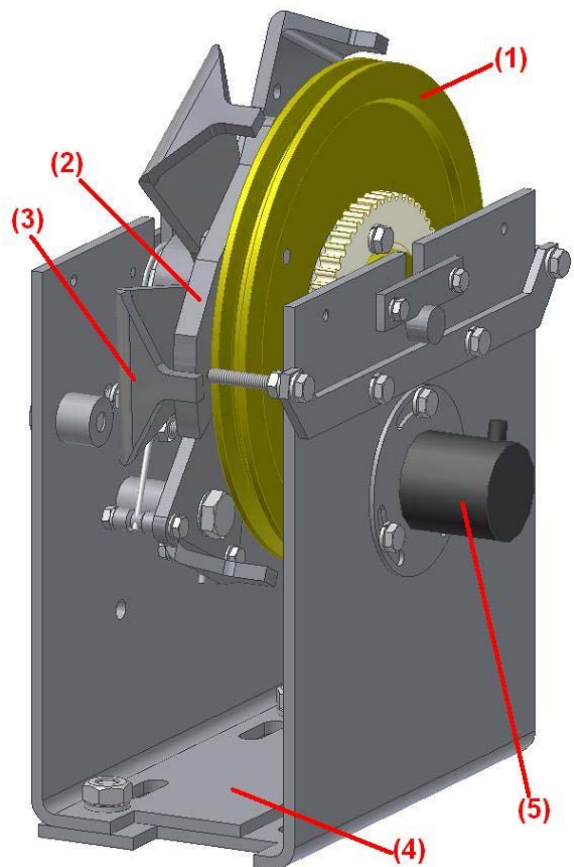

Where:

- (1) – Main pulley.
- (2) – Centrifugal system.
- (3) – Locking system.
- (4) – Floor fixing plate.
- (5) – Encoder

### 3.- WORKING PRINCIPLES.

The governor is of the centrifugal type and is able to work either **upwards** or **downwards**.

The governor is fixed directly to the floor in the machine room or in the upper part of the well, joined by the rope to its tensing pulley located in the pit.

This tensing pulley is attached to the guide pulley by flanges.

The rope passes through the groove of the governor and the tensing pulley.

The ends of the rope are attached to the linkage anchoring. Thus, when the car reaches its tripping speed, the rope-governor relative movement will lock it.

The working diagram is as follows:

- (1) VEGA PLUS governor
- (2) Governor rope
- (3) Tension weight

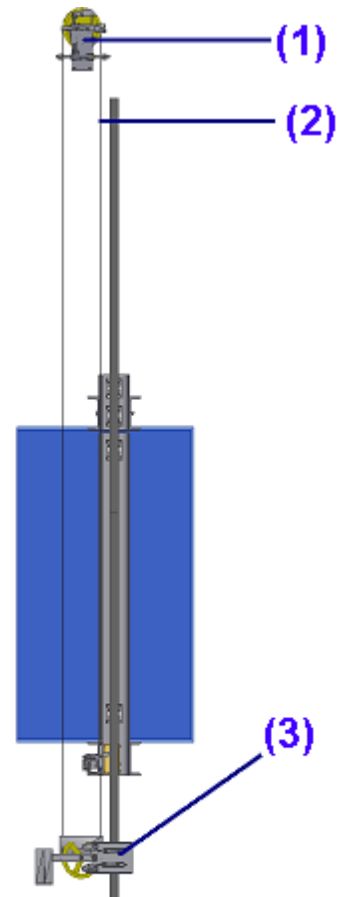

As it was indicated above, the governor is secured to the floor in the machine room or to the well.

A 200 diameter idler will be fitted in the shaft to tighten the rope passing through the governor.

*\*Consult the Vega manual for further details.*

### **3.1. Encoder**

. The VEGA Plus governor is characterised by the fact that it is fitted with an Encoder at the rear for permanent control of the position of the car.

The Encoder turns thanks to a wheel gear system, with a gear ratio of 3. The angular speed at which the encoder turns is 3 times greater than that of the main pulley.

The Encoder supplied in the VEGA plus is the OMRON E6B2CWZ6C500 0.5M 24V.

This is a 500-pulse incremental encoder powered by 24 V.

For further information on the encoder indicated, all the information taken from the OMRON catalogue regarding this product is attached below.

*Note: Clients preferring to install their own encoders should contact Dynatech for measurements and makes of Encoder to ensure that their encoder can be installed in the governor.*

# OMRON

## Rotary Encoder

## E6B2-C

### New General-purpose Incremental Rotary Encoder

- A wide operating voltage range of 5 to 24 VDC (open collector model).
- Resolution of 2,000 pulses/revolution in 40-mm housing.
- Phase Z can be adjusted with ease using the origin indicating function.
- A large load of 30 N in the radial direction and 20 N in the thrust direction is permitted.
- The load short-circuit and reversed connection protecting circuit assures highly reliable operation.
- A line driver output model is available. (Cable extends up to 100 m.)



### Ordering Information

Supply voltage	Output configuration	Resolution (P/R)	Model
5 to 24 VDC	NPN open collector output	10/20/30/40/50/60/100/200/300/360/400/500/600/720/800/1,000/1,024/1,200/1,500/1,800/2,000	E6B2-CWZ6C
12 to 24 VDC	PNP open collector output	100/200/360/500/600/1,000/2,000	E6B2-CWZ5B
5 to 12 VDC	Voltage output	10/20/30/40/50/60/100/200/300/360/400/500/600/1,000/1,200/1,500/1,800/2,000	E6B2-CWZ3E
5 VDC	Line driver output	10/20/30/40/50/60/100/200/300/360/400/500/600/1,000/1,024/1,200/1,500/1,800/2,000	E6B2-CWZ1X

Note: When ordering, specify the resolution together with the model number.

### Accessories (Order Separately)

Name	Model
Coupling	E69-C06B (attachment)
	E69-C68B
	E69-C610B
	E69-C06M
Flange	E69-FBA
	E69-FBA02 (E69-2 Mounting Bracket included)
Mounting Bracket	E69-2

### Application Example

#### Filling Control

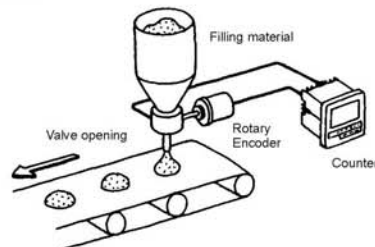

**E6B2-C** ————— **OMRON** ————— **E6B2-C**

## Specifications

### ■ Ratings/Characteristics

#### Electrical

Item	E6B2-CWZ6C	E6B2-CWZ5B	E6B2-CWZ3E	E6B2-CWZ1X
Power supply voltage	5 VDC -5% to 24 VDC +15%	12 VDC -10% to 24 VDC +15%	5 VDC -5% to 12 VDC +10%	5 VDC ±5%
Current consumption (see note 3)	70 mA max.	80 mA max.		130 mA max.
Resolution	10/20/30/40/50/60/100/200/300/360/400/500/600/720/800/1,000/1,024/1,200/1,500/1,800/2,000 P/R	100/200/360/500/600/1,000/2,000 P/R	10/20/30/40/50/60/100/200/300/360/400/500/600/1,000/1,200/1,500/1,800/2,000 P/R	10/20/30/40/50/60/100/200/300/360/400/500/600/1,000/1,024/1,200/1,500/1,800/2,000 P/R
Output phases	A, B, and Z (reversible)			A, $\bar{A}$ , B, $\bar{B}$ , Z, $\bar{Z}$
Output configuration	Open collector	Open collector	Voltage	Line driver (see note 2)
Output capacity	30 VDC max. 35 mA max. Residual voltage: 0.4 V max.	35 mA max. Residual voltage: 0.4 V max.	20 mA max. Residual voltage: 0.4 V max.	AM26LS31 equivalent Output current: High level = $I_o = -20$ mA Low level = $I_s = 20$ mA Output voltage: High level = $V_o = 2.5$ V min. Low level = $V_s = 0.5$ V max.
Max. response frequency (see note 1)	100 kHz	50 kHz	100 kHz	
Phase difference on output	90°±45° between A and B (1/4T±1/8T)			
Rise and fall times of output	1 μs max. (control output voltage: 5 V; load resistance: 1 kΩ; cable length: 0.5 m)	1 μs max. (cable length: 2 m; $I_{sink}$ : 10 mA max.)	1 μs max. (cable length: 0.5 m; $I_{sink}$ : 10 mA max.)	0.1 μs max. (cable length: 0.5 m; $I_o$ : -20 mA; $I_s$ : 20 mA)
Insulation resistance	20 MΩ min. (at 500 VDC) between carry parts and case			
Dielectric strength	500 VAC, 50/60 Hz for 1 min between carry parts and case			

- Note:**
- The maximum electrical response revolution is determined by the resolution and maximum response frequency as follows:  
Maximum electrical response frequency (rpm) = Maximum response frequency/resolution x 60  
This means that the E6B2-C Rotary Encoder will not operate electrically if its revolution exceeds the maximum electrical response revolution.
  - The line driver output is a data transmission circuit compatible with RS-422A and long-distance transmission is possible with a twisted-pair cable.
  - An inrush current of approximately 9 A will flow for approximately 0.3 ms when the power is turned ON.

#### Mechanical

Item	E6B2-CWZ6C	E6B2-CWZ5B	E6B2-CWZ3E	E6B2-CWZ1X
Shaft loading	Radial: 30 N Thrust: 20 N			
Moment of inertia	1 x 10 <sup>-6</sup> kg • m <sup>2</sup> max.; 3 x 10 <sup>-7</sup> kg • m <sup>2</sup> max. at 600 P/R max.			
Starting torque	980 μN • m max.			
Max. permissible revolution	6,000 rpm			
Vibration resistance	Destruction: 10 to 500 Hz, 150 m/s <sup>2</sup> or 2-mm double amplitude for 11 min 3 times each in X, Y, and Z directions			
Shock resistance	Destruction: 1,000 m/s <sup>2</sup> 3 times each in X, Y, and Z directions			
Weight	Approx. 100 g max. (cable length: 0.5 m)			

#### Environmental

Item	E6B2-CWZ6C	E6B2-CWZ5B	E6B2-CWZ3E	E6B2-CWZ1X
Ambient temperature	Operating: -10°C to 70°C (with no icing) Storage: -25°C to 85°C (with no icing)			
Ambient humidity	Operating: 35% to 85% (with no condensation)			
Degree of protection	IEC60529 IP50			

**E6B2-C** ————— **OMRON** ————— **E6B2-C**

## Operation

### ■ Output Circuits

**E6B2-CWZ6C**

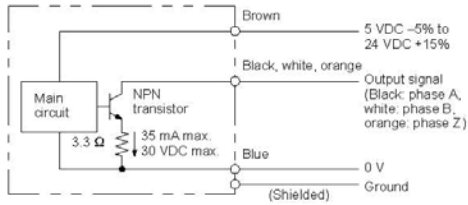

**E6B2-CWZ5B**

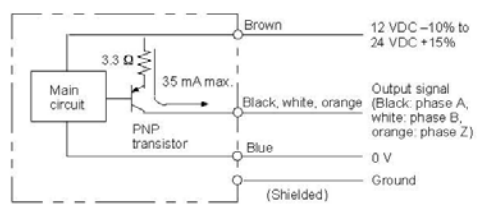

**E6B2-CWZ3E**

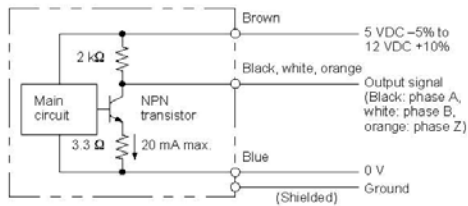

**E6B2-CWZ1X**

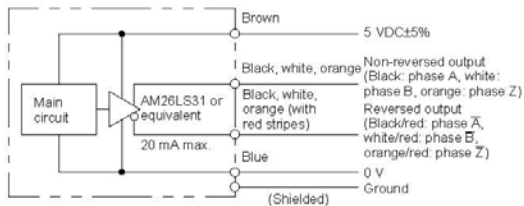

**E6B2-C** **OMRON** **E6B2-C**

**■ Timing Charts**  
**Open Collector Output**  
 E6B2-CWZ6C  
 E6B2-CWZ5B

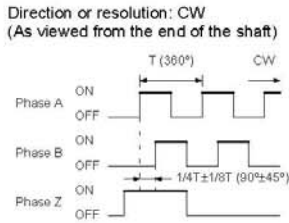

**Note:** Phase A is  $1/4 \pm 1/8T$  faster than phase B. The ONs in the above timing chart mean that the output transistor is ON and the OFFs mean that the output transistor is OFF.

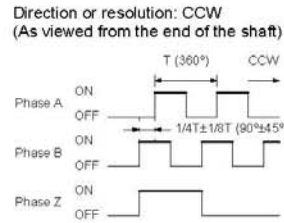

**Note:** Phase A is  $1/4 \pm 1/8T$  slower than phase B.

**Voltage Output**  
 E6B2-CWZ3E

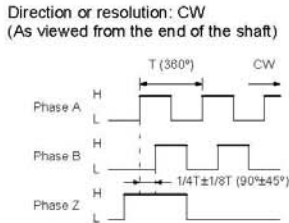

**Note:** Phase A is  $1/4 \pm 1/8T$  faster than phase B.

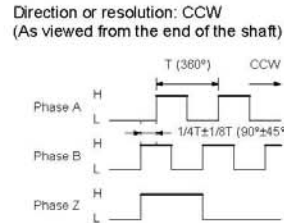

**Note:** Phase A is  $1/4 \pm 1/8T$  slower than phase B.

**Line Driver Output**  
 E6B2-CWZ1X

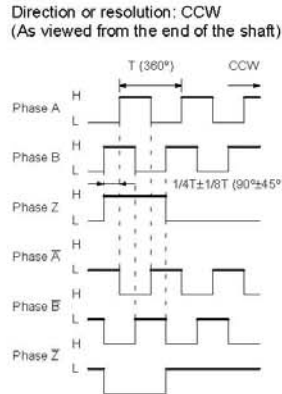
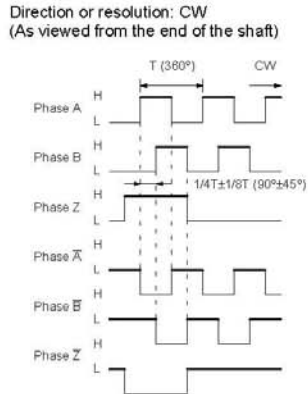

**Note:** The line driver output circuit is an RS-422A data transmission circuit consisting of two balanced output lines. The relationship between the two output lines is on an equal status. This means that if the level of the signal on a line is H, the level of the signal on the other line is L. The noise-resistive line driver output circuit assures high-speed data transmission.

**E6B2-C** ————— **OMRON** ————— **E6B2-C**

■ **Input to More than One Counter from Encoder (with Voltage Output)**

Use the following formula to obtain the number of counters to be connected to a single E6B2-C Rotary Encoder.

$$\text{Number of counters (N)} = \frac{R1 (E-V)}{V \times R2}$$

- E: Voltage supplied to Rotary Encoder
- V: Minimum input voltage of the counter
- R2: Output resistance of the Rotary Encoder
- R1: Input resistance of the counter

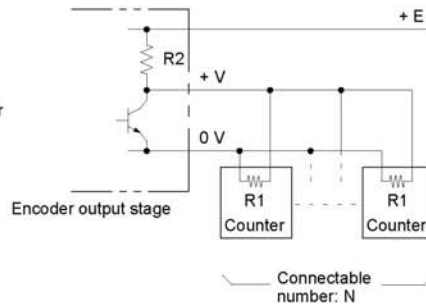

■ **Origin Indication**

It is easy to adjust the position of phase Z with the origin indication function. The following illustration (on the left-hand side) shows the relationship between phase Z and the origin. Set cut face D to the origin as shown in the illustration (on the right-hand side).

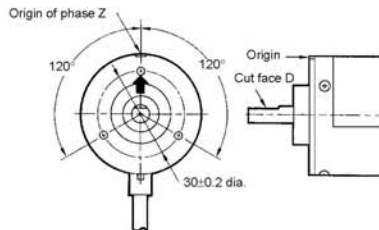

■ **Output Protection Circuit**

The E6B2-C (open collector model with voltage output) incorporates a circuit preventing the E6B2-C from damage due to a short-circuited load and reversed connection.

**E6B2-C** ————— **OMRON** ————— **E6B2-C**

## Dimensions

**Note:** All units are in millimeters unless otherwise indicated.

**E6B2-C**

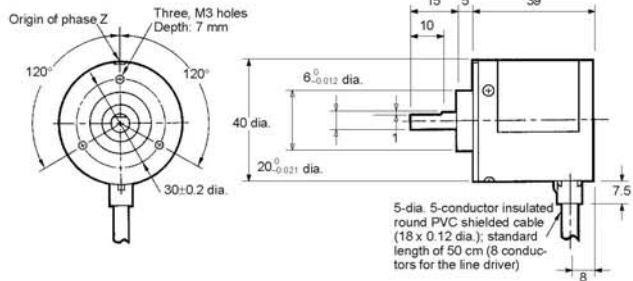

**Coupling E69-C06B (Included)**

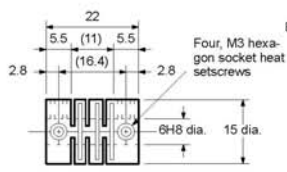

**Note:** The coupling is made of glass-reinforced PBT.

**E69-C68B (Sold Separately, Different Diameter)**

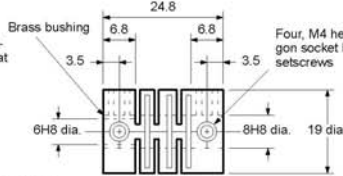

**E69-C610B (Sold Separately, Different Diameter)**

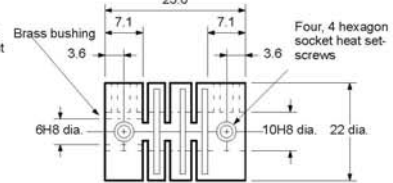

**E69-C06M (Sold Separately, Different Diameter)**

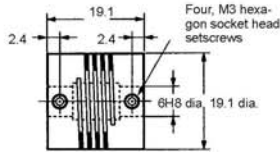

**Note:** The coupling is made of extra super duralumin.

**Flange (Sold Separately)**

**E69-FBA**

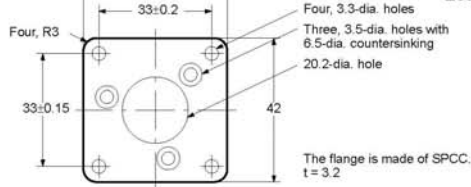

**E69-FBA02**

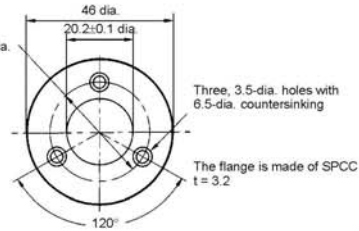

**Mounting Bracket (Three Pieces as a Set) E69-2 (One Set Provided with the E69-FBA02)**

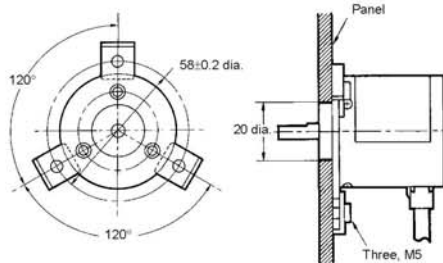
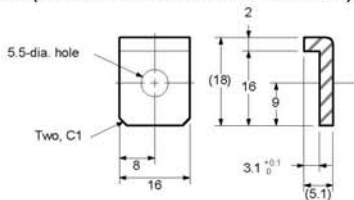

E6B2-C

OMRON

E6B2-C

## Installation

### ■ Connection

Be sure to connect the external terminals correctly or the E6B2-C Rotary Encoder may be damaged.

#### E6B2-CWZ6C/-CWZ5B/-CWZ3E

Color	Terminal
Brown	Power supply (+V <sub>CC</sub> )
Black	Output phase A
White	Output phase B
Orange	Output phase Z
Blue	0 V (common)

#### E6B2-CWZ1X

Color	Terminal
Brown	Power supply (+V <sub>CC</sub> )
Black	Output phase A
White	Output phase B
Orange	Output phase Z
Black/red stripes	Output phase A
White/red stripes	Output phase B
Orange/red stripes	Output phase Z
Blue	0 V (common)

Note: Receiver: AM26LS32 equivalent

- Note:
1. The external conductor (shield) of the shielded cable is not connected to the internal conductors nor to the case.
  2. All the phases A, B, and Z are in the same circuit.
  3. Connect the GND to the 0-V line or to the ground terminal.

### ■ Connections with Peripheral Devices

Coupling	Specification	Resin, standard type				Resin, non-standard opening diameter		Metal	
	Internal shaft diameter (mm)	4 (H8), 13	6 (H8), 15	8 (H8), 19	10 (H8), 22	6/8 (H8), 19	6/10 (H8), 22	6 (H8), 19.1	10 (H8), 25.4
Rotary Encoder	Model	E69-C04B	E69-C06B	E69-C08B	E69-C10B	E69-C68B	E69-C610B	E69-C06M	E69-C10M
<b>E6B2, 6-mm diameter</b>		C	A	C	C	B	B	B	C

- Note:
- A: Possible to connect directly in most cases.
  - B: Possible to connect, but an independent power supply or pull-up resistor will be required.
  - C: Impossible to connect.

### Connection Examples

#### Connection to H7CR-CW Counter

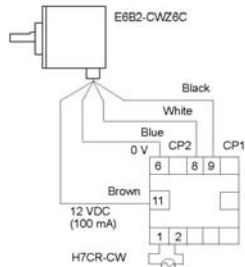

#### Features of H7CR

DIN-sized (DIN 48) counter incorporating a prescale function converting the measured value to the actual value.

Synchronized output and  $\pm$  indication are available ( $\pm$  area models).

Models with a general-purpose six-digit display and four-digit display are available.



#### Connection to K3NR-NB□□□/ K3NP-NB□□□ Rotary Intelligent Signal Processor

#### Features of K3NR/K3NP

Each model incorporates a prescale function with an input range of 50 kHz and the measurement accuracy is 0.006%.

A variety of outputs, including relay, transistor, BCD, linear, and communications outputs, are available.

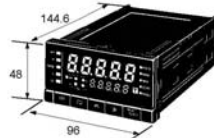

**E6B2-C** ————— **OMRON** ————— **E6B2-C**

**Precautions**

■ **Mounting**  
**Mounting Procedure**

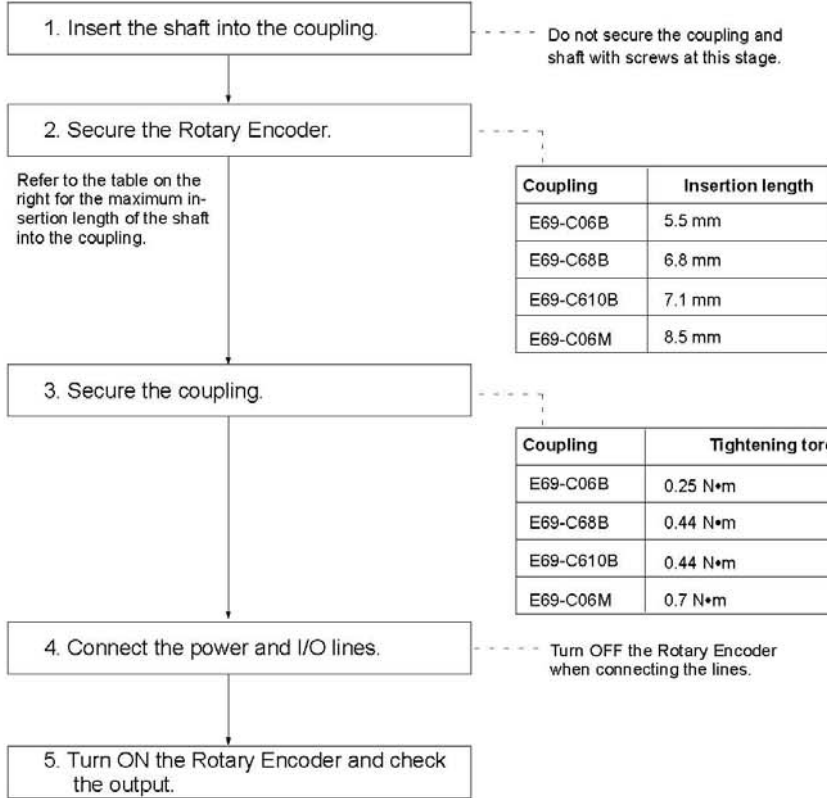

**Installation**

Be careful not to spray water or oil onto the E6B2-C Rotary Encoder. The E6B2-C Rotary Encoder consists of high-precision components. Handle it with utmost care and do not drop the Rotary Encoder, otherwise malfunctioning may result.

When the E6B2-C Rotary Encoder is used in reversing operation, pay utmost attention to the mounting direction of the E6B2-C Rotary Encoder and the directions of increment and decrement rotation.

To match phase Z of the E6B2-C Rotary Encoder and the origin of the device to be connected to the E6B2-C Rotary Encoder, confirm the phase Z output when connecting the device.

Do not impose an excessive load on the shaft if the shaft is connected to a gear.

If the Rotary Encoder is mounted with screws, the tightening torque must be approximately 0.49 N•m.

Refer to the following illustrations when using a standard coupling.

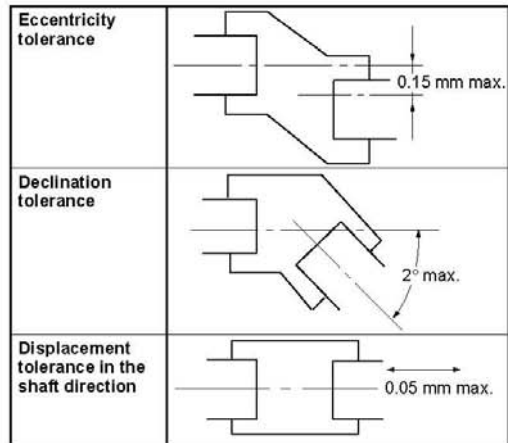

If the eccentricity or declination value exceeds the tolerance, an excessive load imposed on the shaft may damage the Rotary Encoder or shorten the life of the Rotary Encoder.

**Mounting**

When connecting the shaft of the Rotary Encoder with a chain timing belt or gear, connect the chain timing belt or gear with the shaft via the bearing and coupling as shown in the following illustration.

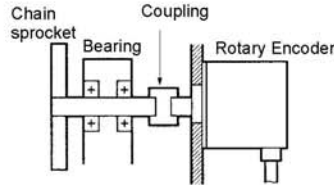

Do not hit the shaft or coupling with a hammer when inserting the shaft into the coupling. No shock must be applied to the shaft or coupling.

When connecting or disconnecting the coupling, do not bend, press, or pull the coupling excessively.

**Bearing Life**

The following graph shows the life expectancy (theoretical values) of the bearing with radial and thrust loads imposed on the bearing.

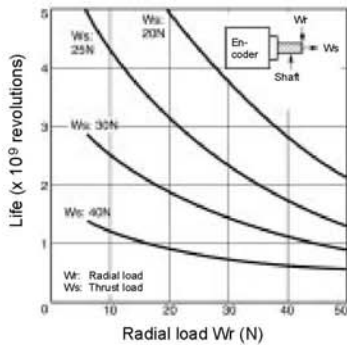

**Wiring**

If the Rotary Encoder is mounted in a panel, do not pull the cable with more than a force of 29.4 N.

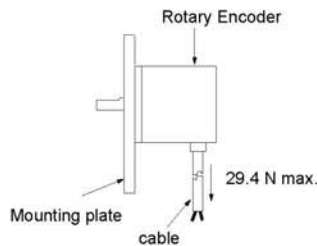

Do not pull the cable of the E6B2-C rotary Encoder after the E6B2-C Rotary Encoder is mounted to a panel. Do not apply any shock to the hollow shaft or the body.

**Connections**

When extending the cable, select the kind of cable with care, taking the response frequency into consideration. The longer the cable is, the more the residual voltage increases due to the resistance of the cable and the capacitance between the wires. As a result, the waveform will be distorted.

OMRON recommends models with a line driver output if the cable needs to be extended.

To reduce inductive noise, the cable must be laid the shortest distance, especially when the signal is input to an IC.

Insert a surge absorber between the power supply terminals if there is any surge.

To reduce noise, the total cable length must be as short as possible. Incorrect pulses may be generated when the E6B2-C Rotary Encoder is turned ON or OFF. Do not use the connected device for 0.1 s after the E6B2-C Rotary Encoder is turned ON and for 0.1 s before the E6B2-C Rotary Encoder is turned OFF.

**Cable Extension**

The rise time of each output waveform will increase when the cable is extended. This will affect the phase difference characteristics of phases A and B.

The rise time varies with the resistance of the cable, the kind of cable, and the length of the cable.

The residual output voltage will increase according to the length of the cable.

**E6B2-CWZ6C**

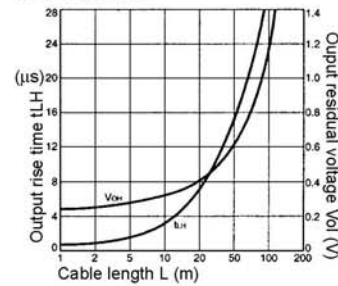

**Measurement example**

- Power supply voltage: 5 VDC
- Load resistance: 1 k $\Omega$
- (Residual output voltage was measured at a load current of 35 mA.)
- Cable: Dedicated cable

**Preventing Miscounting**

If the operation of the E6B2-C Rotary Encoder is stopped near a signal rising or falling edge, incorrect pulses may be generated, in which case the E6B2-C Rotary Encoder will miscount. Use an increment-decrement counter to prevent miscounting.

**E6B2-C** ————— **OMRON** ————— **E6B2-C**

**Extension of Line Driver Output**

Use twisted-pair cable to extend the line driver cable.  
 Recommended cable: Tachii Densen's TKVVBS4P-02A  
 Use an RS-422A receiver.

The twisted-pair wires shown in the following illustration are suitable for RS-422A signal transmission. Normal mode noise can be eliminated by twisting the wires because the generated electrical forces on the lines cancel each other.

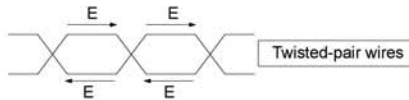

Check that the E6B2-C is supplied with 5 VDC when a line driver output is used. There will be an approximately 1 V voltage drop if the cable length is 100 m.

**Using a Line Receiver IC**

Recommended IC: Texas Instruments

**AM26LS32, AM26C32**

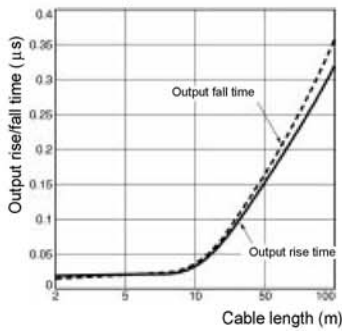

**Others**

**Input to More than One Counter from Rotary Encoder (with Voltage Output)**

Use the following formula to obtain the number of counters to be connected to a single E6B2-C Rotary Encoder.

$$\text{Number of counters (N)} = \frac{R1(E-V)}{V \cdot R2}$$

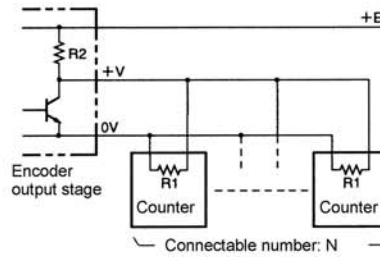

- E: Voltage supplied to Rotary Encoder
- V: Minimum input voltage of the counter
- R1: Input resistance of the Rotary Encoder
- R2: Output resistance of the Rotary Encoder

#### **4.- TECHNICAL FEATURES.**

- **Machine:** Overspeed governor
- **Model:** VEGA PLUS
- **Manufacturing company:**  
DYNATECH, DYNAMICS & TECHNOLOGY, S.L.
- **Range of use:**  
Minimum rated speed: 0.1 m/s  
Maximum rated speed: 2.40 m/s  
Remark: For tripping speeds below 1 m/s, a low speed pulley with a special centrifugal system for low speed will be used.
- **Rope:**  
Diameter: 6 mm, 6.3 mm, 6.5 mm.  
Composition: 6 x 19 + 1
- **Rope pre-tightness:**  
500 N  
This tightness is achieved by positioning the tension weight so that the bar is horizontal.
- **Tightness produced on the rope during interlocking:**  
Greater than 300 N
- **Pulley diameter:** 200 mm
- **Overspeed contact.**
- **Other features:**
  - It is possible to install several devices:
    - Remote tripping system (24, 48, 190 V DC)
    - Remote reset (24, 48, 190 V DC)
    - Encoder OMRON 500 pulses (shaft 6 mm)
    - Hardened Groove (optional)
    - Parking System (24, 48, 190 V DC)
    - Possibility of Unidirectional

- **Safety gears with which it may be used:**

All safety gears with a tripping speed that can be reached by the overspeed governor.

**5.-INSTRUCTIONS OF USE AND MAINTENANCE.**

The instructions and advice for use and maintenance of the governor are exactly the same as for the VEGA governor.

In the case of the encoder, make sure that it contains no dirt and check for any anomalies such as strange noises or sudden movements.

**6.-INSTALLATION DRAWINGS.**

The following drawings may be of help when adapting and installing the VEGA overspeed governor:

Front view:

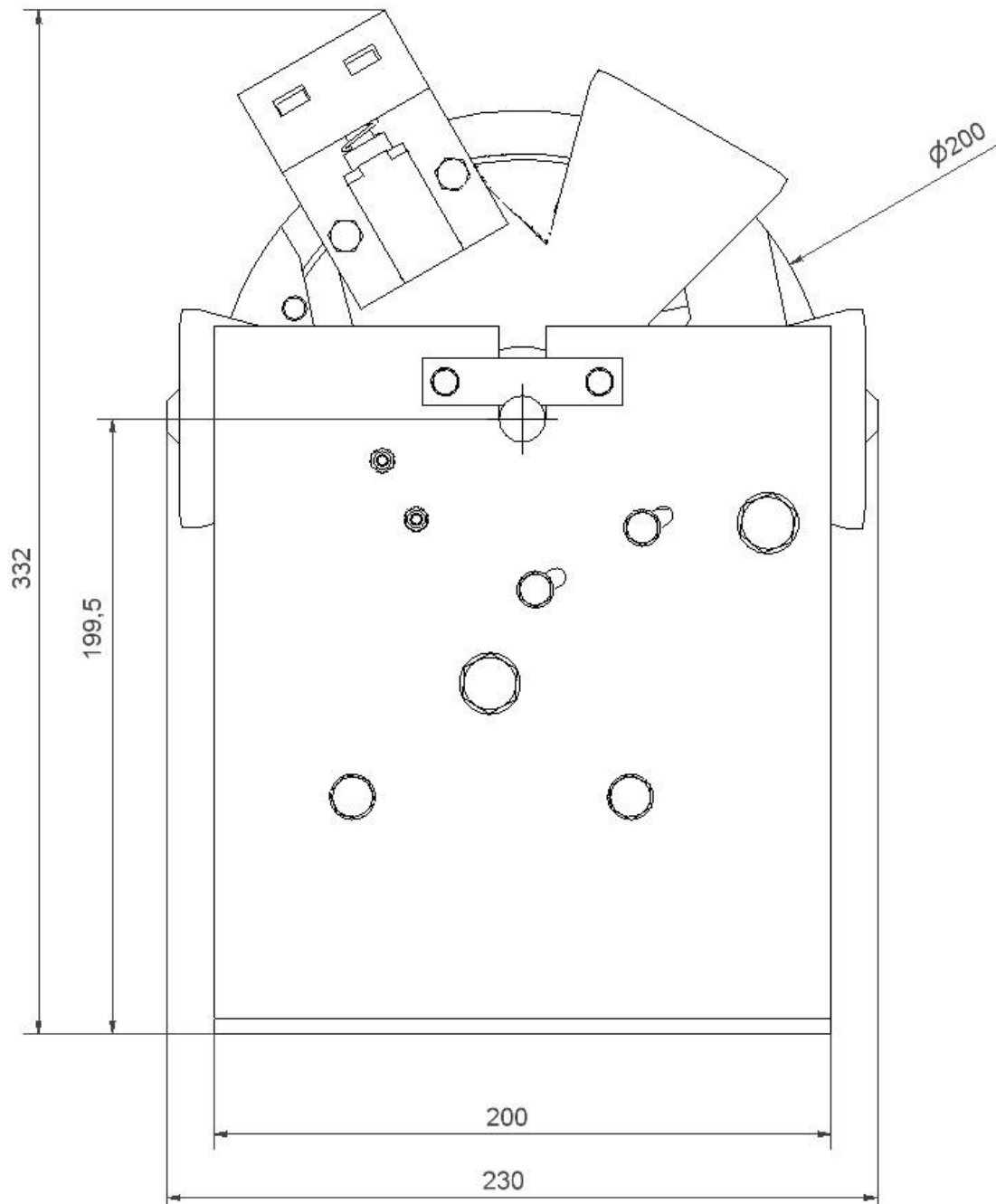

Side view:

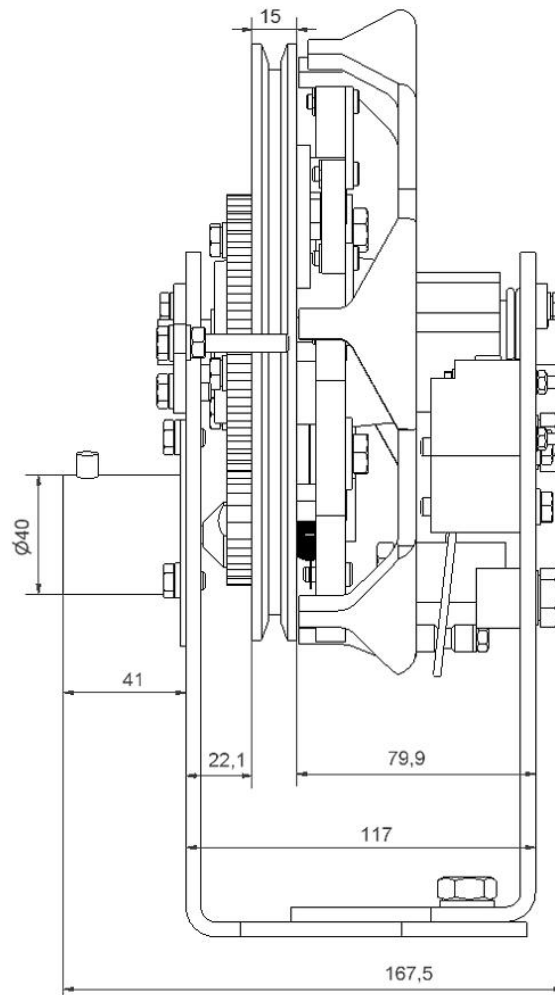

Bottom view:

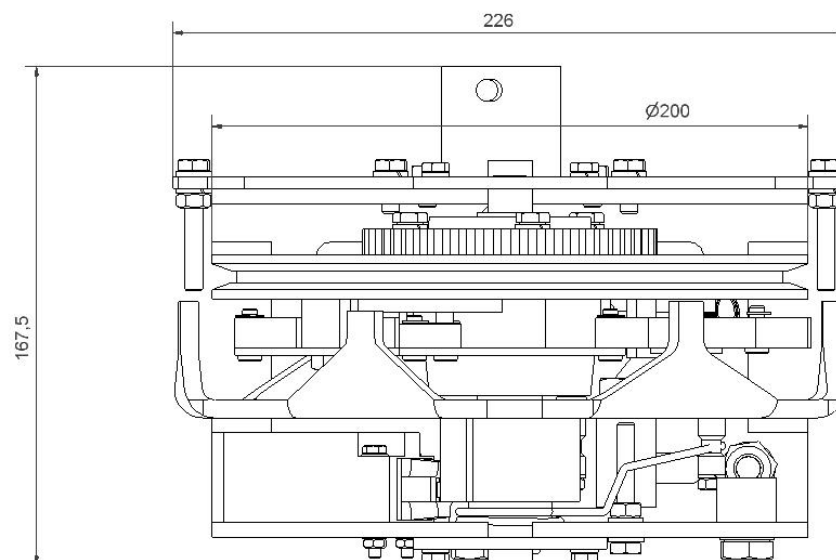

## **7.- EC TYPE-EXAMINATION CERTIFICATE.**

The certificate for VEGA PLUS is the same for VEGA, so check the instructions of the overspeed governor