

**TIMONERIA EXTENSIBILE T2/**

**T2 EXTENSIBLE DRIVING BAR/**

**BARRE DE COMMANDE EXTENSIBLE T2/**

**AUSZIEHBARE AUSLÖSEGESTÄNGE T2**

## **1- INTRODUCTION**

## **2- USE AND MAINTENANCE INSTRUCTIONS**

## **3- ASSEMBLY HANDBOOK**

## **1- INTRODUCTION**

The Dynatech extensible driving bars are the perfect complement for every sling maker who use our progressive and instantaneous safety gears system. Compatibility, simplicity and usefulness are the main criteria followed during its design. The result is an important costs saving for our clients.

The only work required is the positioning of the safety gear in the sling. After that, every component supplied by Dynatech will be installed in a standard way, without the requirement of any modification, included those caused by the distances between guides because the driving bars are extensibles.

The sling making cost is considerably reduced due to its standard production, reaching the following objectives:

- Decreasing of the number of work hours of the people in charge of the sling making.
- Decreasing of the number of work hours of the people in charge of the product quality control.
- Financial costs saving (Costs produced by the considerable stocks of the different sling-making elements which would have been needed).
- Delivery time reduction of the product to the client.
- General standardization in all ways: Manufacturing devices, packing, labeling, documentary order, etc....

All these points must be taken in care in order to obtain a good benefit and a great competitiveness for your enterprise.

## **2- USE AND MAINTENANCE INSTRUCTIONS**

All the components are very simple and do not need a special maintenance.

The most important points that must be considered are these:

- 1- The assembly instructions of each driving bar must be respected.
- 2- The screws for the adjustment and fixing of the driving bars to the sling and those for the components of the driving bar have to be tightened with his respective tightening torque in order to guarantee the proper fixing and avoid a wrong driving bar action.
- 3- The driving bar situation in the sling must be correct in order to allow the correct safety gear action as well as avoid the interference of the driving bar with the hollow devices or the guides.
- 4- Knocks and dents must be avoided.

### 3.-T2 DRIVING BAR ASSEMBLY HANDBOOK

1. Once received, the T2 DRIVING BAR should be unpacked and it should be checked that all its components have been received in good conditions (see enclosed components list, FC-10-09 format).

**2. ARMS AND HANDLES ASSEMBLY:** Each arm (3) must be joined to an arm support (2), through a M8 x 25 DIN 912 screws (5) and a serrated washer DIN 6798 M8 (30). Once

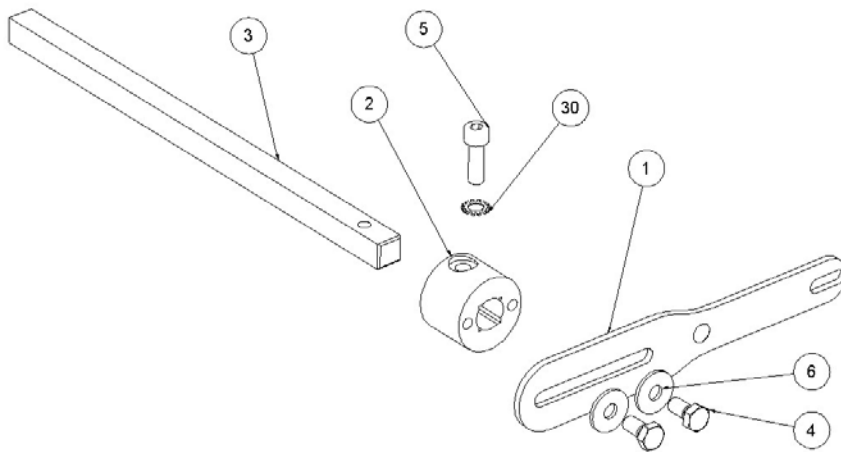

**Figure. 1**

together, they must be joined to a handle (1), through two M8 x 16 DIN 933 screws (4) and two washers DIN 9021 M8 (6), making sure that the countersink of the handle is on its inner face, -Fig. 1-.

**3. GOVERNOR LINKAGE PLACING:** One of the screwed arms must be fixed to the governor linkage (7) through the M10 x 25 DIN 7991 screw (8) and the M10 DIN 985 Autoblock nut (9) -Fig. 2-.

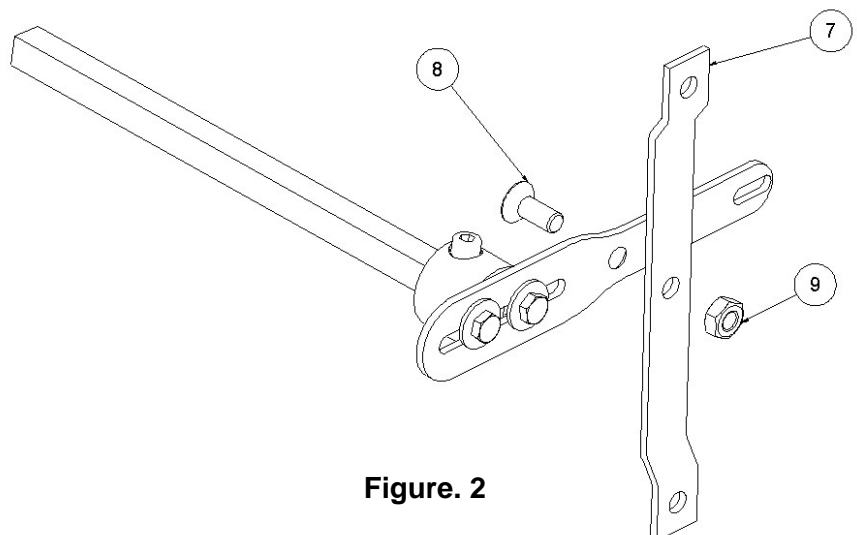
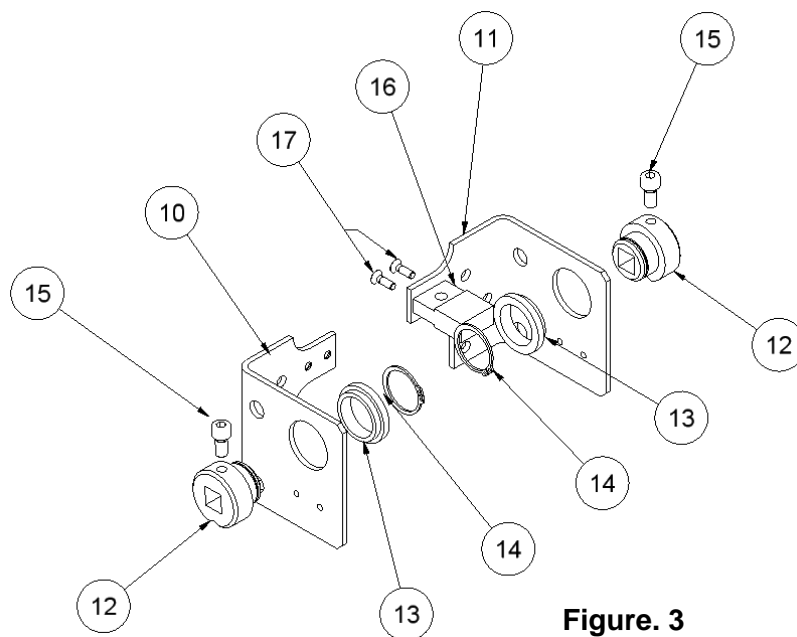

**Figure. 2**

#### 4. MOUNTING PLATES ASSEMBLY:

It must be taken in care during the assembly the fact that the left mounting plate is different than the right one ( **10** y **11** ) Make sure that the holes for the electrical switch remain always in the lower part. (See -Fig. 3-).

The nylon tips (**13**) must be introduced in each mounting plate in the way shown at Fig.3, later on, the support caps (**12**), must be inserted from the opposite side (with the V milling in the lower part), joining them through a security ring M30 x 1,5 DIN 471 (**14**),

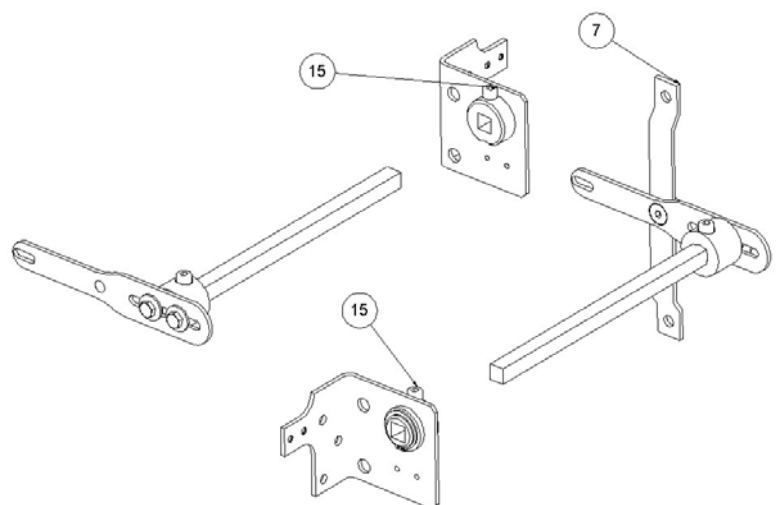

**Figure. 3**

(with the help of straight-end pliers). Finally, an M8 x 16 DIN 912 screw (**15**). must be introduced in each cap.

It is useful in this moment to screw the tensor support (**16**) It should be located in the same side that the governor linkage through two M5 x 10 DIN 7991 (**17**) screws. The whole process is shown at Figure.3.

**5. MOUNTING PLATES AND ARMS JOINT:** Before joining the mounting plates and the arms, it should be checked which is the right plate and which is the left one. The arm with the governor linkage must be introduced in the plate on the side where the lift speed governor is placed and the arm without the governor linkage (**7**) will be introduced in the other plate. The support cap screw (**15**) must be tightened in order to fix together the mounting plates and the arms -Fig. 4-.



**Figure. 4**

It is recommendable to fix definitively the screw after having placed the driving bar at the sling in order to improve its adjustment at the sling.

**6. DRIVING BAR AXLE PLACING:** The joined arms must be introduced in endings of the driving bar axle (18) and must be screwed through M6 x 20 DIN 912 screws (19). The width of the driving bar can be adjusted introducing more or less the arms into the axle - Fig.5-.

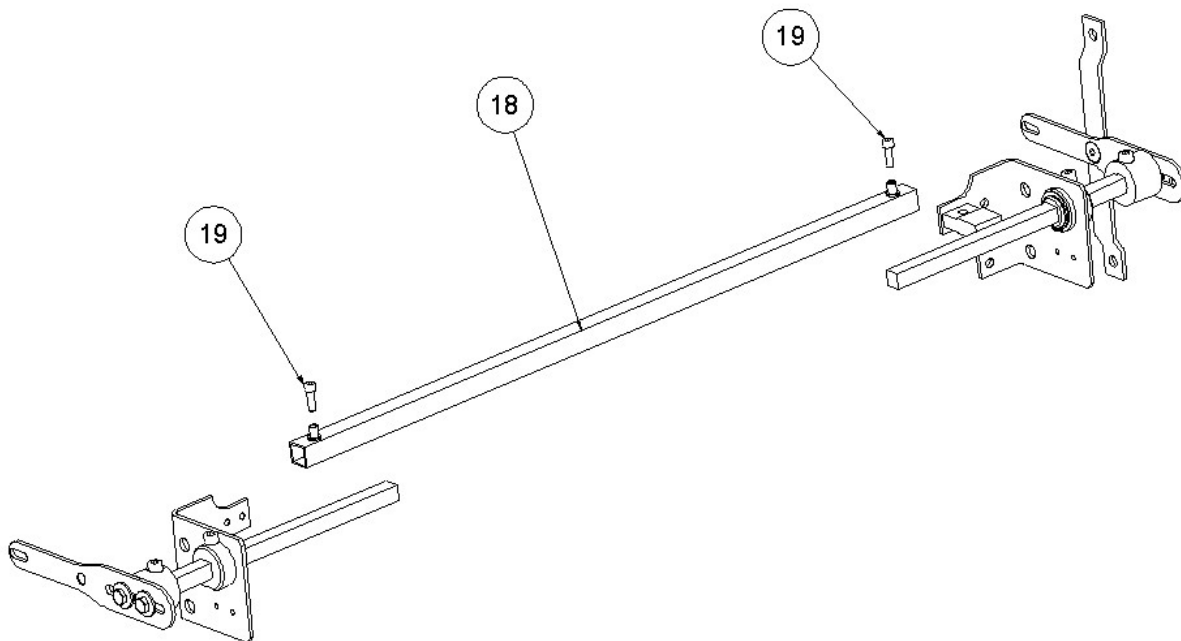

**Figure. 5**

The definitive fixing of the screws should be done after being placed the driving bar at the sling in order to center the axle to the lift sling. In order to avoid damaging the autoscrewed nuts, please do not apply an excessive torque while screwing.

**7. TENSOR GROUP ASSEMBLY:** The two axle supports (20) must be aligned with the tensing support (one in upper part and other in lower part), then insert the tensing tip (21) and fix this group with the M6 X 35 DIN 933 screw (22) and M6 DIN 985 Autoblock nut (23). Next, the M8 X 100 DIN 931 screw (25), must be introduced in the free drill holes placed at the axle supports and through the spring (24), as can be seen in the figure. Finally the group is fixed by a M8 DIN 125 washer (26) and a M8 DIN 985 Autoblock nut (27) -Fig.6-.

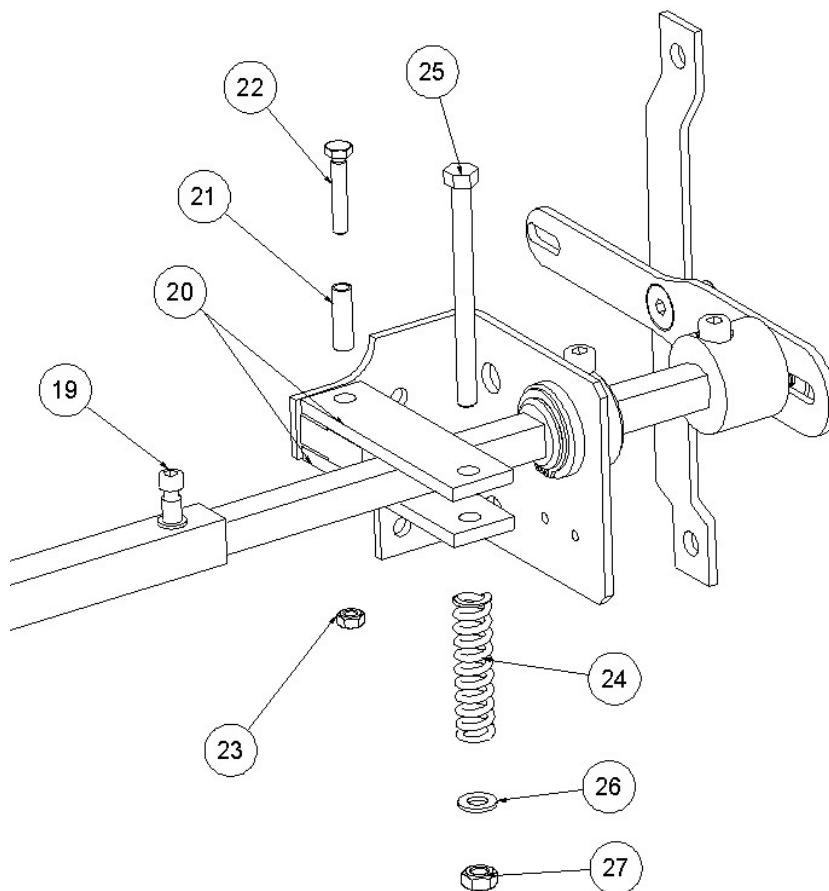

**Figure. 6**

The tensor group must be assembled in the mounting plates at the side of the governor linkage.

Once placed the driving bar and the safety gears, the last thing that must be done is to situate the drill or circlip at the trolley (PR-2500-UD V.35)

The handle must be fixed making sure that the driving bar keeps the trolley at the center position of the safety gear.

Optionally, Dynatech also offers the electrical switch, which is needed to cut current when safety gear is activated. See Figure 7.

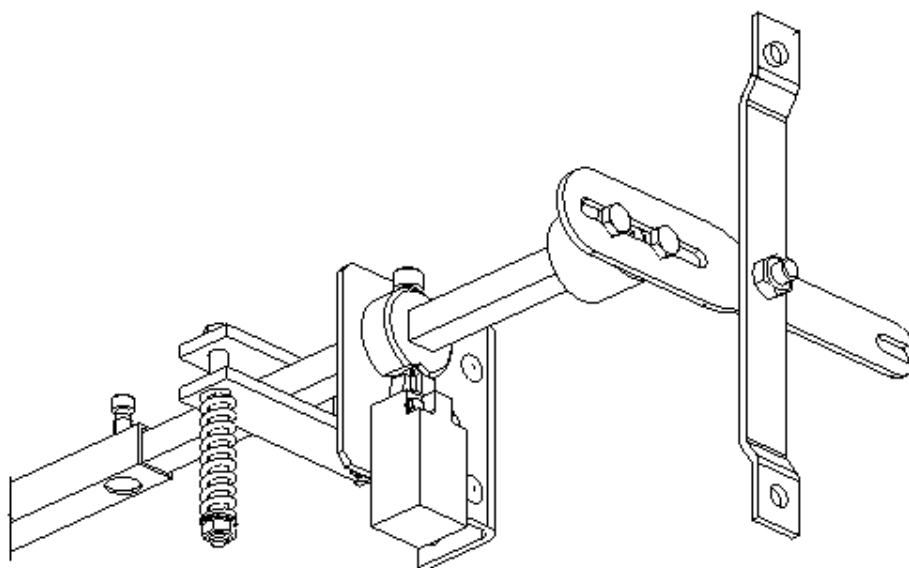

**Figure. 7**

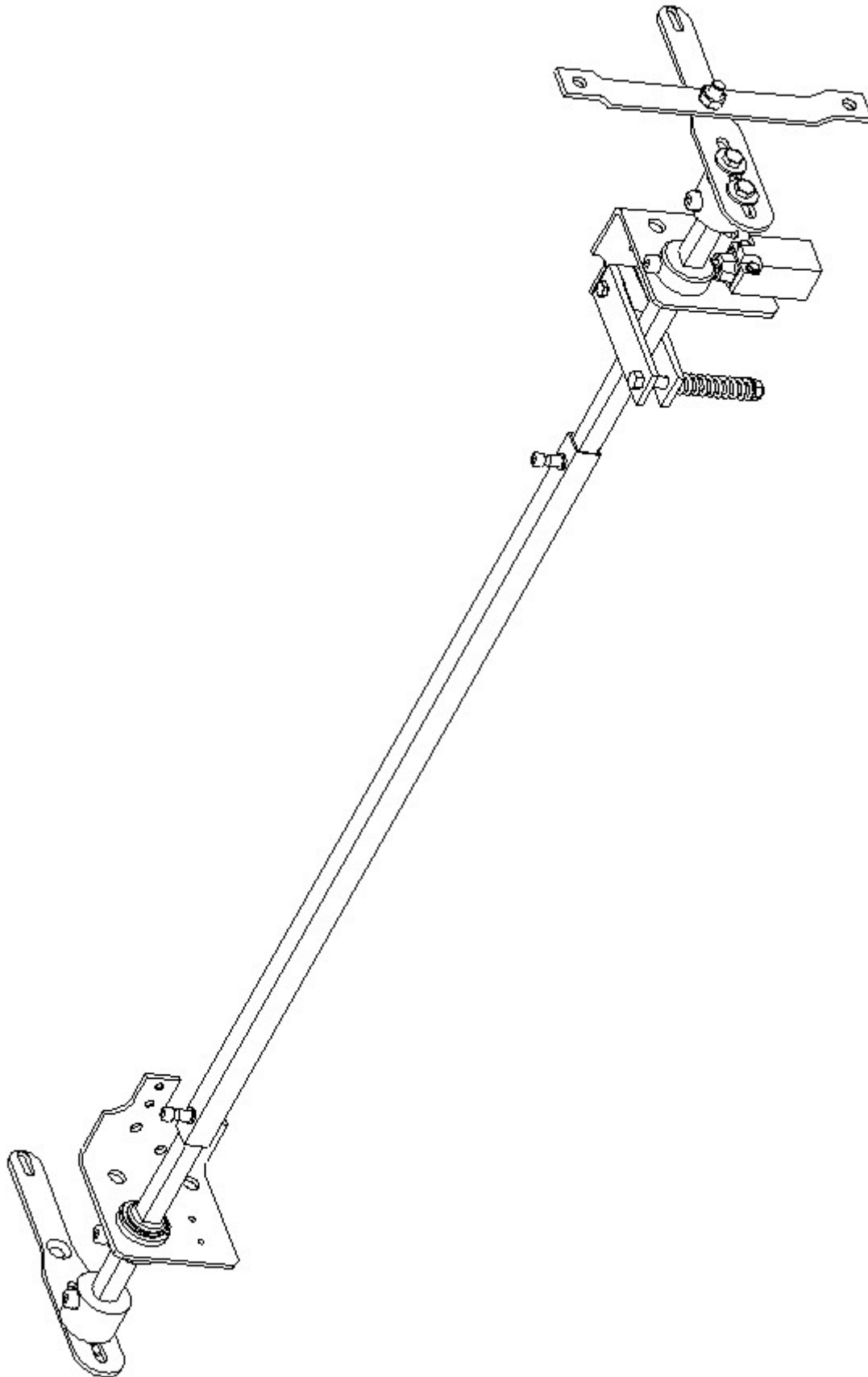

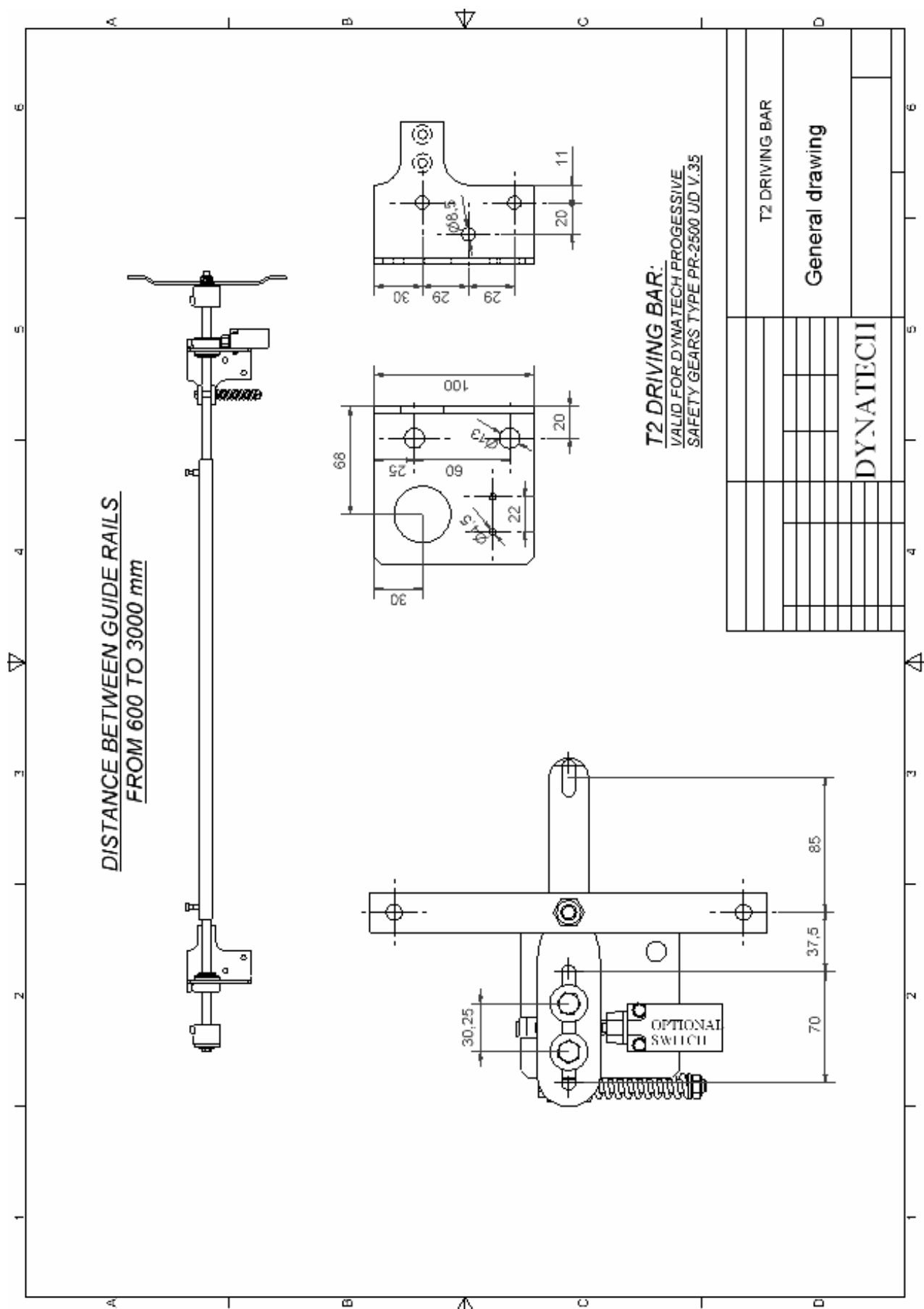

<b>DYNATECH</b> DYNAMICS & TECHNOLOGY	IDENTIFICACIÓN DE LOS COMPONENTES DE LA TIMONERÍA T2 T2 DRIVING BAR COMPONENTS IDENTIFICATION	REVISIÓN/ CHECK/ RÉVISION/ STAND	04	FECHA/ DATE/ DATE/ DATUM	15/12/2011
	IDENTIFICATION DES COMPOSANTS DE LA BARRE DE COMMANDE T2 KENNZEICHNUNG GESTÄNGERBAUTEILE T2	CÓDIGO/ CODE/ CODE/ CODE	FC-10-09	PÁGINA/ PAGE/ PAGE/ SEITE	1 / 2



1 Placa base izquierda/  
 Left mounting plate/  
 Plaque base gauche/  
 Grundplatte links

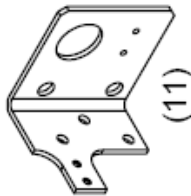

1 Placa base derecha/  
 Right mounting plate/  
 Plaque base droite/  
 Grundplatte rechts



2 Bujes de apoyo/  
 Supports caps/  
 Bagues appui/  
 Stütznapfen



2 Casquillos de nylon/  
 Nylon tips/  
 Douilles nylon/  
 Nylon büchse/

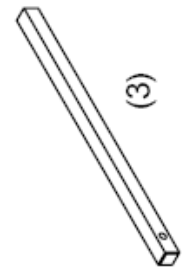

2 Ejes brazo/  
 Arms axles/  
 Axes bras/  
 Armachsen/



1 Amarre limitador/  
 Governor linkage/  
 Arrimage limiteur/  
 Begrenzerbefestigung

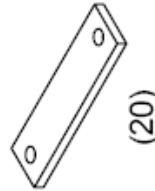

2 Soportes eje/  
 Axle Supports/  
 Support axe/  
 Achsenhalter



1 Eje timonería/  
 Driving bar axle/  
 Axe barre de commande/  
 Gestängeachse



1 Muelle/  
 Spring/  
 Ressort/  
 Feder

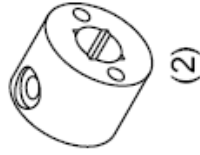

2 Soportes brazo/  
 Arm supports/  
 Supports bras/  
 Armhalter



2 Tiradores/  
 Handles/  
 Tireurs/  
 Zuggriffe

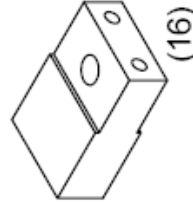

1 Soporte tensor/  
 Tensing Support/  
 Support Tendeur/  
 Spannhalter

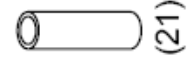

1 Casquillo tensor/  
 Tensing Tip/  
 Douille tendeur/  
 Spannhülse

<b>DYNATECH</b> DYNAMICS & TECHNOLOGY	IDENTIFICACIÓN DE LOS COMPONENTES DE LA TIMONERÍA T2 IDENTIFICATION OF THE COMPONENTS OF THE T2 DRIVING BAR IDENTIFICATION DES COMPOSANTS DE LA BARRE DE COMMANDE T2 BEZEICHNUNG DE COMPONENTEN DES AUSLÖSEGESTÄNGE T2	REVISIÓN/ CHECK/ REVISION/ STAND	04	FECHA/ DATE/ DATE/ DATUM	15/12/2011
		CODIGO/ CODE/ CODE/ CODE	FC-10-09	PÁGINA/ PAGE/ PAGE/ SEITE	2 / 2

**TORNILLERÍA DE LA TIMONERÍA T2 / SCREWS OF THE T2 DRIVING BAR / VISSERIE DE LA BARRE DE COMMANDE T2 / SCHRAUBEN DES AUSLÖSEGESTÄNGE T2**

- 4 Tornillos / Screws / Vises / Schrauben DIN 933 8.8 M8x16
- 1 Tornillo / Screw / Vis / Schraube DIN 933 8.8 M6x35
- 1 Tornillo / Screw / Vis / Schraube DIN 931 8.8 M8x100
- 2 Tornillos / Screws / Vises / Schrauben DIN 912 8.8 M8x25
- 2 Tornillos / Screws / Vises / Schrauben DIN 912 8.8 M8x16
- 2 Tornillos / Screws / Vises / Schrauben DIN 912 8.8 M6x20
- 1 Tornillo / Screw / Vis / Schraube DIN 7991 10.9 M10x25
- 2 Tornillos / Screws / Vises / Schrauben DIN 7991 10.9 M5x10
- 1 Tuerca Autoblock/ Autoblock Nut / Écrou Autoblock / Selbstsicherende Mutter DIN 985 M10
- 1 Tuerca Autoblock / Autoblock Nut / Écrou Autoblock / Selbstsicherende Mutter DIN 985 M8
- 1 Tuerca Autoblock / Autoblock Nut / Écrou Autoblock / Selbstsicherende Mutter DIN 985 M6
- 1 Arandela plana / Washer / Rondelle / Sicherheitsflachscheibe DIN 125 M8
- 2 Anillos de seguridad / Security rings / Anneaux de sûreté/ Sicherheitsringe DIN 471 30x1,5
- 4 Arandelas de ala ancha / Washer / Rondelles / Unterlegscheiben DIN 9021 M8
- 2 Arandelas dentadas / Serrated washer / Rondelles éventails / Fächerscheibe DIN 6798 M8