

INSTRUCTIONS: Tension Pulley 300 (LBD-300)



Date: 10-01-12

Check: 06

TENSION PULLEY 300

INSTRUCTIONS: Tension Pulley 300 (LBD-300)



Date: 10-01-12

Check: 06

1- INSTRUCTIONS FOR USE AND MAINTENANCE

2- ASSEMBLY HANDBOOK

1- INSTRUCTIONS FOR USE AND MAINTENANCE

All the components are very simple and do not need a special maintenance.

The most important points that must be considered are these:

1- The assembly instructions of each tension pulley must be respected.

2- The screws for the adjustment and fixing of the tension pulleys to the guide and those for the components of the Tension Pulley have to be tightened with his respective tightening torque in order to guarantee the proper fixing and avoid a wrong tension pulley action.

3- The tension pulley situation in the guide must be correct so that the rope running in the pulley of the overspeed governor and the tension pulley, circulate properly. In this way the decreasing of the rope life can be avoided , as far as the groove of the pulley.

4- Knocks and dents must be avoided.

2.- ASSEMBLY HANDBOOK OF THE TENSION PULLEY 300

1. Once received, the Tension Pulley 300 should be unpacked and it should be checked that all its components have been received in good conditions (see enclosed components list, FC-10-40 format).

2. ASSEMBLY OF THE CONTACT SUPPORT WITH THE GUIDE HITCH: First the

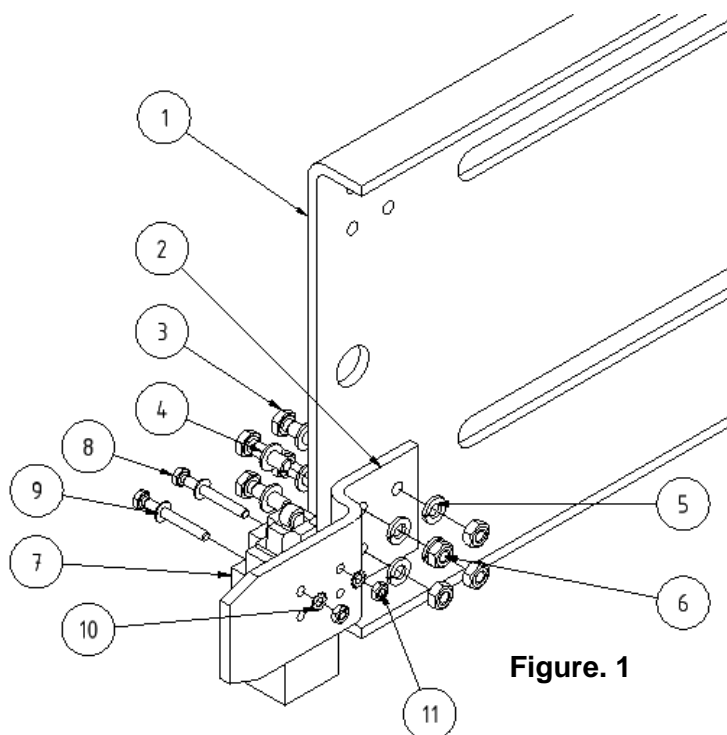

contact support will be joined **(2)**, with the guide hitch **(1)** by 4 screws DIN 933 M6x20 **(3)** with 4 washers DIN 125 M6 **(4)**. Then they will be fixed with 4 grower washers Grower DIN 127 M6 **(5)** and 4 nuts DIN 934 M6 **(6)**. After that the slackening contact **(7)** in the contact support **(2)**, by 2 screws DIN 933 M4x35 **(8)**, and 2 washers DIN 125 M4 **(9)**, then they will be fixed with 2 toothed washers DIN 6798 M4 **(10)**, y two nuts DIN 934 M4 **(11)**.

3. PLACING OF THE WEIGHTSUPPORT BAR IN THE GUIDE HITCH: Insert the hexagonal tip **(12)**, in the hole of the guide hitch **(1)**. It must be joined by a grower washer DIN 127 M18 **(13)** and a nut DIN 936 M18 **(14)**. Once the hexagonal tip is fixed, insert the shaft of the weight support bar ensemble **(15)** in the hexagonal tip, insert a security ring DIN 471 D=14 **(16)**, in order to avoid its release.

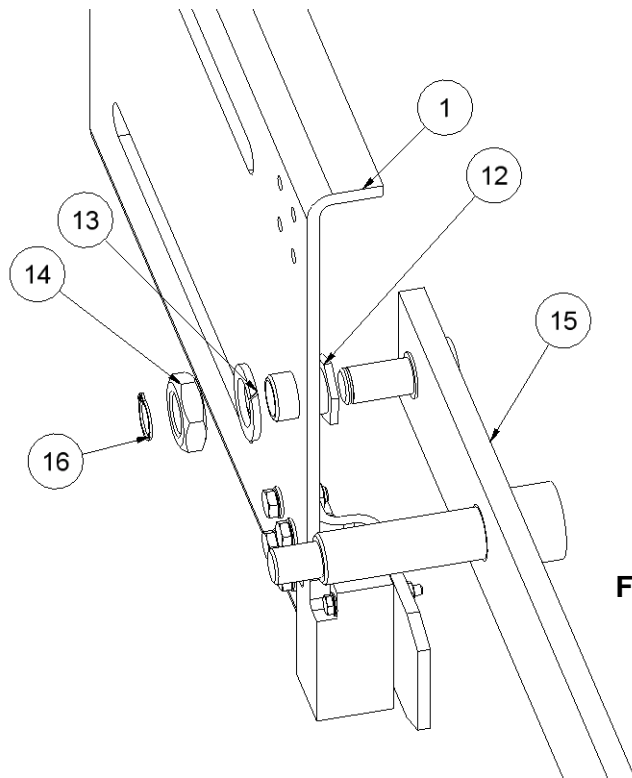

Figure. 2

-Fig. 2-

4. ASSEMBLY OF THE PULLEY IN THE WEIGHTSUPPORT BAR:

First insert a tip **(17)** in the shaft of the weight support bar **(18)**. The pulley will be inserted in the shaft of the weight support bar.

In order to insert properly the pulley in the shaft, place the bearing ball in the shaft straight. The adjustment of the shaft and the bearing ball should be with a hammer. Use a pipe placed in the internal ring of the bearing. Hit the pipe with the nylon hammer until the pulley make a stop in the tip.

Insert a nylon ring **(19)**. -Fig.3-

Date: 10-01-12

Check: 06

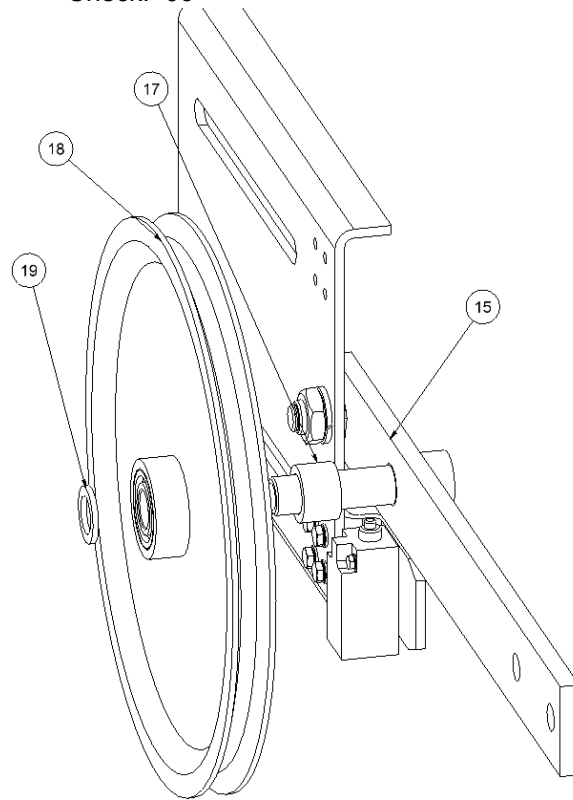

Figure. 3

5. ASSEMBLY OF THE PROTECTION PLATE AND THE UNRELEASED ROPE SYSTEM:

Insert the protection plate **(20)** on the thread of the shaft. Place the plate parallel to the weight support bar. Fix it with a washer DIN 125 M14 **(24)** and one Autoblock nut DIN 985 M14 **(25)**.

The rope out protection consists of two screws DIN 933 M5x45 **(21)**. Insert them in the protection plate. They will be fixed with two washers DIN 125 M5 **(22)** and two nuts DIN 934 M5 **(23)** -Fig. 4-.

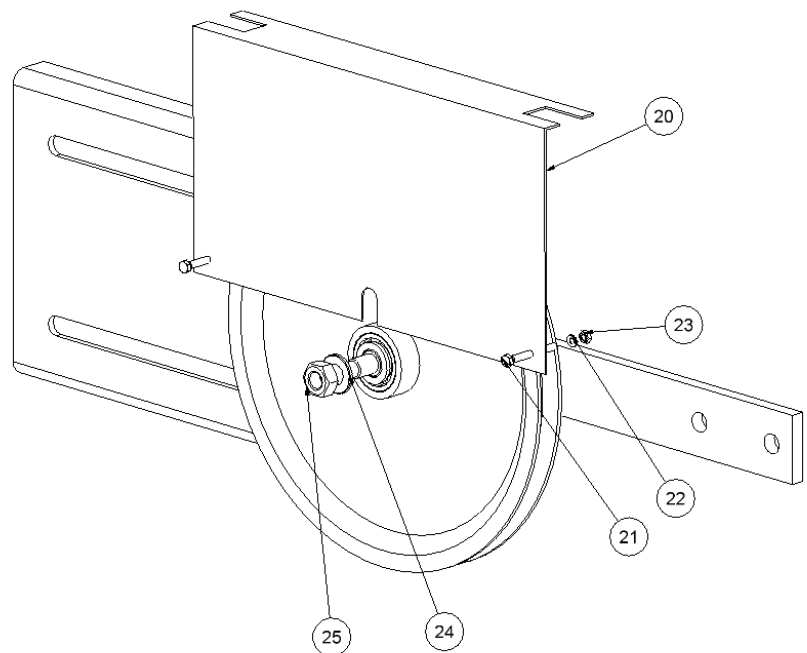

Figure. 4

6. PLACING OF THE TENSION PULLEY IN THE GUIDE:

In order to place the tension pulley, use M14 forgel clips **(26)**.

Place the ensemble in a straight way and screw (not completely) the forgel clips as appears in the figure.

Note: Check visually that the hitch guide plate is on perpendicular position to the guide.

-Fig.5-

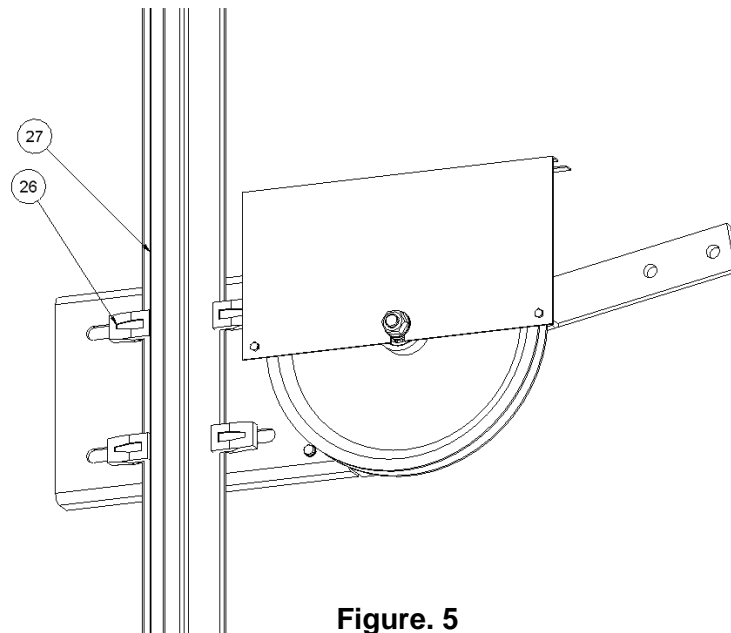

Figure. 5

7. PLACING OF THE ROPE:

Once the tension pulley is placed the rope will be inserted in the groove of the pulley and inside the screws of the rope out protection system.

The weight support bar **(15)**, must be as it's shown in the figure more or less., since when the weights tensioning the rope will be joined to the bar, the pulley tension ensemble must be in straight position.

So, in order to get the weight support bar in the mentioned position, the ensemble will have to descend, use a Nylon hammer to hit in the hitch guide plate til the position of the tension pulley is the position shown in the figure 6.

Once placed properly, screw strongly the forgel clips on the guide.

Note: The tension Pulley must be straight except the weight support bar.

The forgel clips hitched to the guide will have to be straight so that the subjection surface be maximum. -Fig.6-

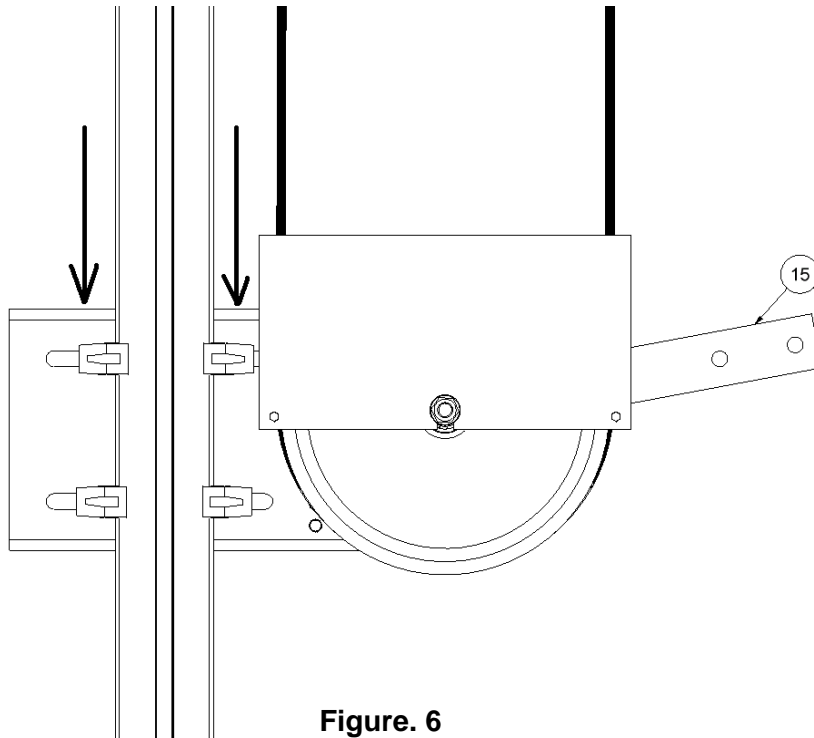

Figure. 6

8. ASSEMBLY OF THE WEIGHTS IN THE TENSION PULLEY: The weights (29) will

have to be joined in the position as it shown in the Figure 7. Use two screws DIN 931 M14x80 (30). Fix them with two Grover washers DIN 127 M14 (32), two washers DIN 125 M14 (31) and two nuts DIN 934 M14 (33).

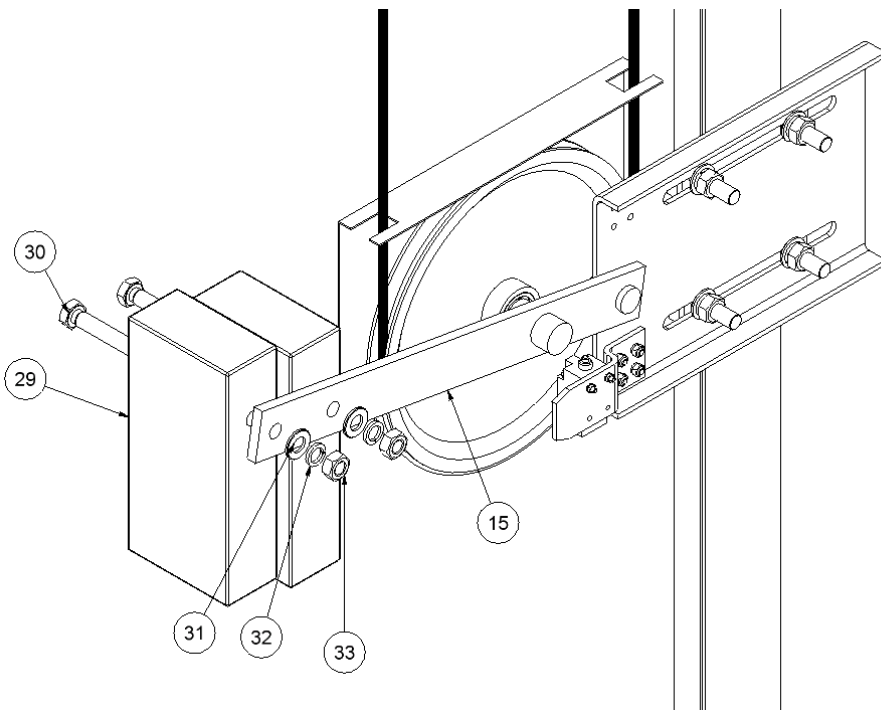

Figure. 7

The Tension pulley will be as it is shown in the Figure 8.

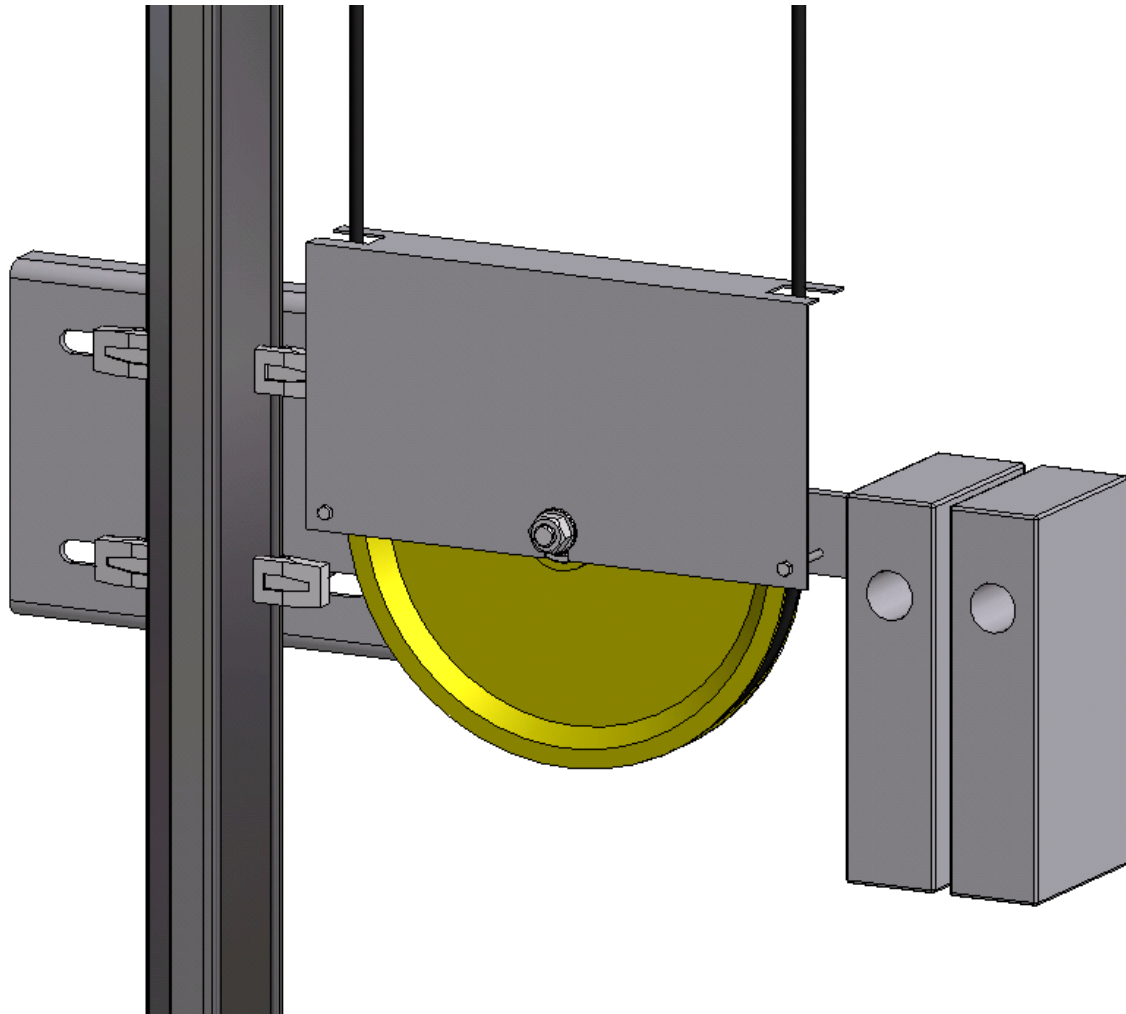
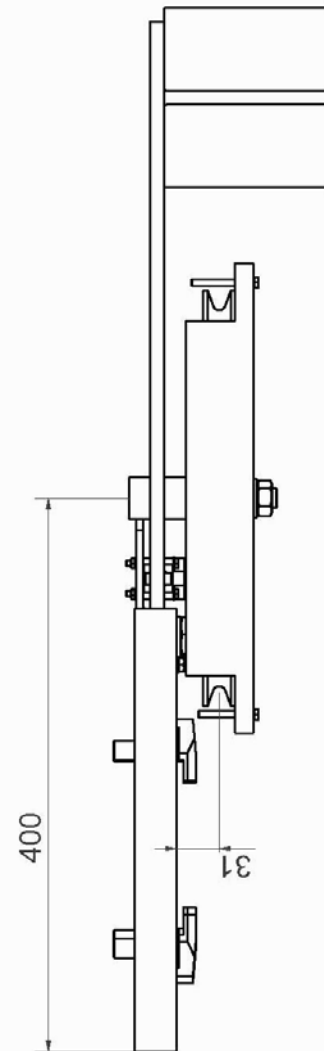
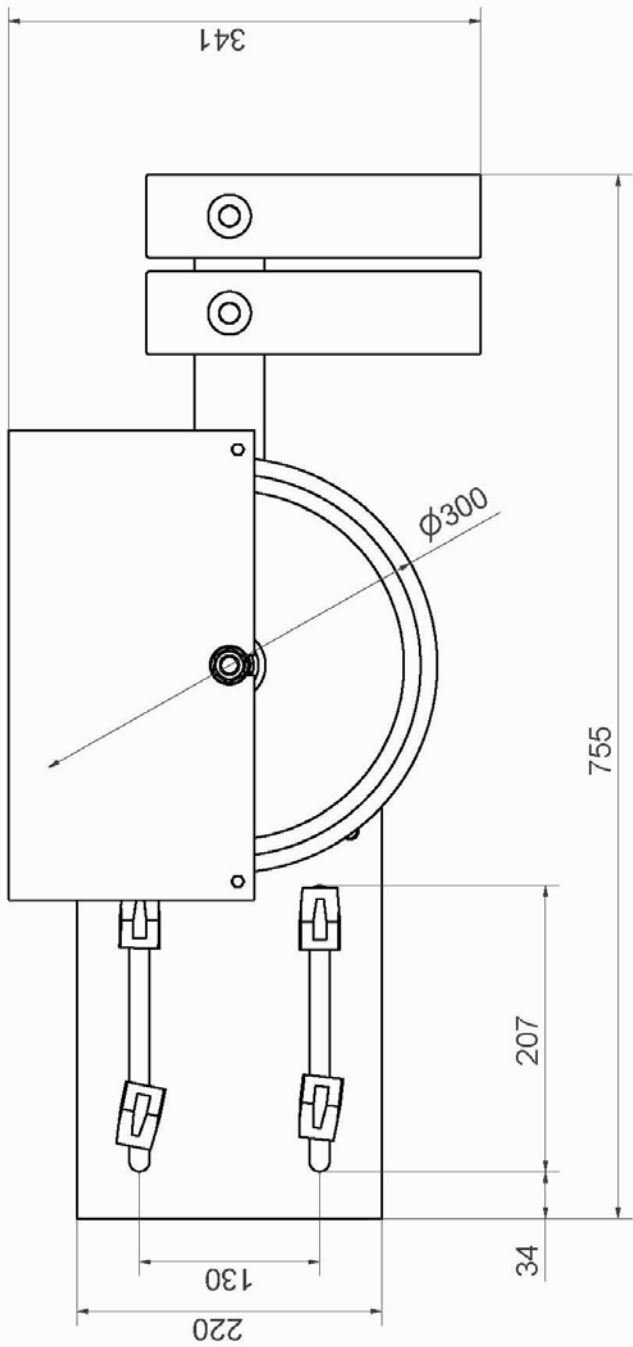
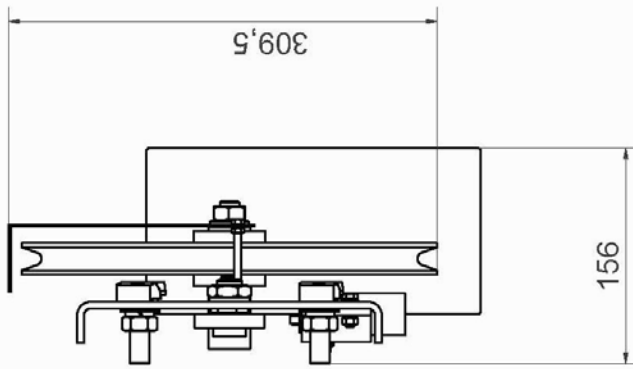
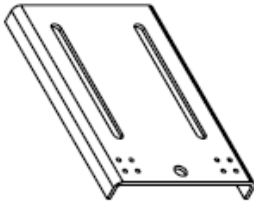
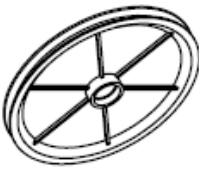
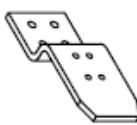
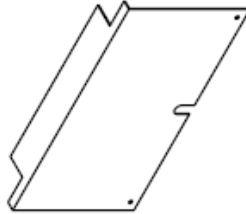
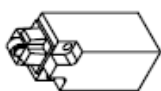
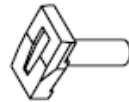
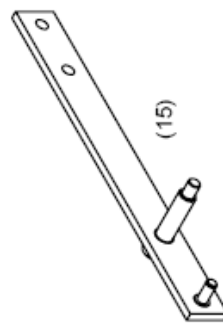
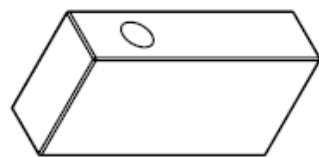

Figure. 8



DYNATECH DYNAMICS & TECHNOLOGY	IDENTIFICACIÓN DE LOS COMPONENTES DE LA POLEA TENSORA 300 TENSION PULLEY 300 COMPONENTS IDENTIFICATION	REVISIÓN/ CHECK/ REVISION/ STAND	05	FECHA/ DATE/ DATE/ DATUM	09 / 01 / 12
	IDENTIFICATION DES COMPOSANTS DE LA POULIER DE TENSION 300 BEZEICHNUNG DER KOMPONENTEN DER SPANNROLLE 300	CÓDIGO/ CODE/ CODE/ CODE	FC-10-40	PÁGINA/ PAGE/ PAGE/ SEITE	1 / 2

<p>1 Amarre guía/ Guide hitch/ Arrimage guide/ Führungsbefestigung</p>  <p>(1)</p>	<p>1 Polea (con rodamientos)/ Pulley (with bearings)/ Poulie (avec roulements)/ Rolle (mit Kugellager)</p>  <p>(18)</p>
<p>1 Soporte Contacto/ Contact support/ Support contact/ Kontakthalterung</p>  <p>(2)</p>	<p>1 Tapa/ Protection Plate/ Couvercle/ Abdeckung</p>  <p>(20)</p>
<p>1 Contacto destensamiento/ Slackening contact/ Contact de relâchement/ Entspannkontakt</p>  <p>(7)</p>	<p>4 Bidas Forjadas/ Forged clips/ Brides Forgées/ Schmiedeflansche</p>  <p>(26)</p>
<p>1 Barra Portapesas/ Weights support bar/ Barre porte-poids/ Gewichtsträgerstange</p>  <p>(15)</p>	<p>2 Pesas/ Weights/ Poids/ Gewichtes</p>  <p>(29)</p>

Date: 10-01-12

Check: 06

DYNATECH DYNAMICS & TECHNOLOGY	IDENTIFICACIÓN DE LOS COMPONENTES DE LA POLEA TENSORA 300 TENSION PULLEY 300 COMPONENTS IDENTIFICATION	REVISIÓN/ CHECK/ REVISION/ STAND	05	FECHA/ DATE/ DATE/ DATUM	09 / 01 / 12
	IDENTIFICATION DES COMPOSANTS DE LA POULIERE DE TENSION 300 BEZEICHNUNG DER KOMPONENTEN DER SPANNROLLE 300	CÓDIGO/ CODE/ CODE/ CODE	FC-10-40	PÁGINA/ PAGE/ PAGE/ SEITE	2 / 2

TORNILLERÍA DE LA POLEA TENSORA 300 / SCREWS IN THE TENSION PULLEY 300 / VISSERIE DE LA POULIERE DE TENSION 300 / SCHRAUBENARTIKEL FÜR DIE SPANROLLE 300

- 2 Tornillos / Screws / Vises / Schrauben DIN 931 8.8 M14x80
 4 Tornillos / Screws / Vises / Schrauben DIN 933 8.8 M6x20
 2 Tornillos / Screws / Vises / Schrauben DIN 933 8.8 M5x45
 2 Tornillos / Screws / Vises / Schrauben DIN 933 8.8 M4x35
 3 Arandelas / Washers / Rondelles / Unterlegscheiben DIN 125 M14
 4 Arandelas / Washers / Rondelles / Unterlegscheiben DIN 125 M6
 2 Arandelas / Washers / Rondelles / Unterlegscheiben DIN 125 M5
 2 Arandelas / Washers / Rondelles / Unterlegscheiben DIN 125 M4
 1 Arandela / Washer / Rondelle / Unterlegscheiben DIN 127 M18
 2 Arandelas Grower / Washers Grower / Rondelles Grower / Federring DIN 127 M14
 4 Arandelas Grower / Washers Grower / Rondelles Grower / Federring DIN 127 M6
 2 Arandelas dentadas / Toothed washers / Rondelles Dentées / Zahnscheiben DIN 6798 M4.
 2 Tuercas / Nuts / Écrous / Mutterm DIN 934 M4
 2 Tuercas / Nuts / Écrous / Mutterm DIN 934 M5
 4 Tuercas / Nuts / Écrous / Mutterm DIN 934 M6
 2 Tuercas / Nuts / Écrous / Mutterm DIN 934 M14
 1 Tuerca Autoblock / Autoblock Nut / Écrous Autoblock / Autoblockmutter DIN 985 M14
 1 Tuerca / Nut / Écrou / Mutter DIN 936 M18
 1 Anillo de Seguridad / Security Ring / Bague de Sûreté / Sicherheitsring DIN 471 Eje / Axle / Achse 12



1 Casquillo/
Tip/
Douille/
Buchse
(17)



2 Anillo Nylon/
Nylon Ring/
Bagues Nylon/
Nylonringe
(19)



1 Casquillo Hexagonal/
Hexagonal Tip/
Douille Hexagonale/
Sechskantbuckse
(12)

FC-10-40

DYNATECH DYNAMICS & TECHNOLOGY	DESPIECE DE LOS ELEMENTOS DE LA POLEA TENSORA 300 TENSION PULLEY 300 COMPONENTS IDENTIFICATION DÉPEÇAGE DES COMPOSANTS DE LA POULIE DE TENSION 300 STÜCKLISTE DER KOMPONENTEN DER SPANNROLLE 300	REVISION/ CHECK/ REVISION/ STAND 01	FECHA/ DATE/ DATE/ DATUM 10 / 01 / 12
		CÓDIGO/ CODE/ CODE/ CODE FC-10-62	PÁGINA/ PAGE/ PAGE/ SEITE 1 / 1

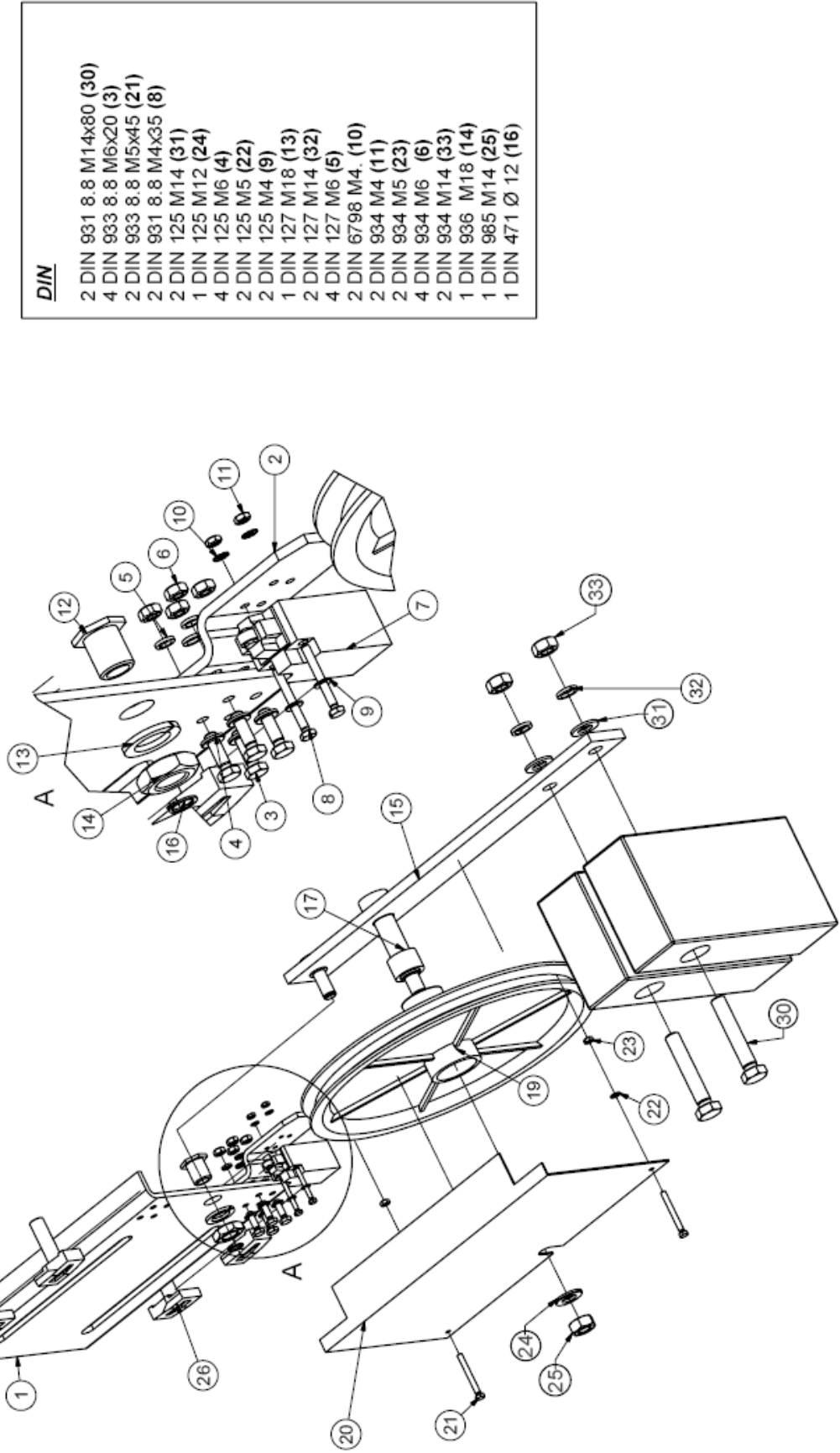

<u>DIN</u>	
2	DIN 931 8.8 M14x80 (30)
4	DIN 933 8.8 M6x20 (3)
2	DIN 933 8.8 M5x45 (21)
2	DIN 931 8.8 M4x35 (8)
2	DIN 125 M14 (31)
1	DIN 125 M12 (24)
4	DIN 125 M6 (4)
2	DIN 125 M5 (22)
2	DIN 125 M4 (9)
1	DIN 127 M18 (13)
2	DIN 127 M14 (32)
4	DIN 127 M6 (5)
2	DIN 6798 M4 (10)
2	DIN 934 M4 (11)
2	DIN 934 M5 (23)
4	DIN 934 M6 (6)
2	DIN 934 M14 (33)
1	DIN 936 M18 (14)
1	DIN 985 M14 (25)
1	DIN 471 Ø 12 (16)